

PC-TIO-10

User Manual

Timing I/O Board for the PC

July 1993 Edition

Part Number 320292-01

**© Copyright 1990, 1994 National Instruments Corporation.
All Rights Reserved.**

National Instruments Corporate Headquarters

6504 Bridge Point Parkway

Austin, TX 78730-5039

(512) 794-0100

Technical support fax: (800) 328-2203

(512) 794-5678

Branch Offices:

Australia (03) 879 9422, Austria (0662) 435986, Belgium 02/757.00.20, Canada (Ontario) (519) 622-9310,

Canada (Québec) (514) 694-8521, Denmark 45 76 26 00, Finland (90) 527 2321, France (1) 48 14 24 24,

Germany 089/741 31 30, Italy 02/48301892, Japan (03) 3788-1921, Mexico 95 800 010 0793,

Netherlands 03480-33466, Norway 32-84 84 00, Singapore 2265886, Spain (91) 640 0085, Sweden 08-730 49 70,

Switzerland 056/20 51 51, Taiwan 02 377 1200, U.K. 0635 523545

Limited Warranty

The PC-TIO-10 is warranted against defects in materials and workmanship for a period of one year from the date of shipment, as evidenced by receipts or other documentation. National Instruments will, at its option, repair or replace equipment that proves to be defective during the warranty period. This warranty includes parts and labor.

The media on which you receive National Instruments software are warranted not to fail to execute programming instructions, due to defects in materials and workmanship, for a period of 90 days from date of shipment, as evidenced by receipts or other documentation. National Instruments will, at its option, repair or replace software media that do not execute programming instructions if National Instruments receives notice of such defects during the warranty period. National Instruments does not warrant that the operation of the software shall be uninterrupted or error free.

A Return Material Authorization (RMA) number must be obtained from the factory and clearly marked on the outside of the package before any equipment will be accepted for warranty work. National Instruments will pay the shipping costs of returning to the owner parts which are covered by warranty.

National Instruments believes that the information in this manual is accurate. The document has been carefully reviewed for technical accuracy. In the event that technical or typographical errors exist, National Instruments reserves the right to make changes to subsequent editions of this document without prior notice to holders of this edition. The reader should consult National Instruments if errors are suspected. In no event shall National Instruments be liable for any damages arising out of or related to this document or the information contained in it.

EXCEPT AS SPECIFIED HEREIN, NATIONAL INSTRUMENTS MAKES NO WARRANTIES, EXPRESS OR IMPLIED, AND SPECIFICALLY DISCLAIMS ANY WARRANTY OF MERCHANTABILITY OR FITNESS FOR A PARTICULAR PURPOSE. CUSTOMER'S RIGHT TO RECOVER DAMAGES CAUSED BY FAULT OR NEGLIGENCE ON THE PART OF NATIONAL INSTRUMENTS SHALL BE LIMITED TO THE AMOUNT THEREFORE PAID BY THE CUSTOMER. NATIONAL INSTRUMENTS WILL NOT BE LIABLE FOR DAMAGES RESULTING FROM LOSS OF DATA, PROFITS, USE OF PRODUCTS, OR INCIDENTAL OR CONSEQUENTIAL DAMAGES, EVEN IF ADVISED OF THE POSSIBILITY THEREOF. This limitation of the liability of National Instruments will apply regardless of the form of action, whether in contract or tort, including negligence. Any action against National Instruments must be brought within one year after the cause of action accrues. National Instruments shall not be liable for any delay in performance due to causes beyond its reasonable control. The warranty provided herein does not cover damages, defects, malfunctions, or service failures caused by owner's failure to follow the National Instruments installation, operation, or maintenance instructions; owner's modification of the product; owner's abuse, misuse, or negligent acts; and power failure or surges, fire, flood, accident, actions of third parties, or other events outside reasonable control.

Copyright

Under the copyright laws, this publication may not be reproduced or transmitted in any form, electronic or mechanical, including photocopying, recording, storing in an information retrieval system, or translating, in whole or in part, without the prior written consent of National Instruments Corporation.

Trademarks

LabVIEW[®], LabWindows[®], and NI-DAQ[™] are trademarks of National Instruments Corporation.

Product and company names listed are trademarks or trade names of their respective companies.

WARNING REGARDING MEDICAL AND CLINICAL USE OF NATIONAL INSTRUMENTS PRODUCTS

National Instruments products are not designed with components and testing intended to ensure a level of reliability suitable for use in treatment and diagnosis of humans. Applications of National Instruments products involving medical or clinical treatment can create a potential for accidental injury caused by product failure, or by errors on the part of the user or application designer. Any use or application of National Instruments products for or involving medical or clinical treatment must be performed by properly trained and qualified medical personnel, and all traditional medical safeguards, equipment, and procedures that are appropriate in the particular situation to prevent serious injury or death should always continue to be used when National Instruments products are being used. National Instruments products are NOT intended to be a substitute for any form of established process, procedure, or equipment used to monitor or safeguard human health and safety in medical or clinical treatment.

Preface

Introduction to the PC-TIO-10

This manual describes the mechanical and electrical aspects of the PC-TIO-10 and contains information concerning its operation and programming. The PC-TIO-10 is a timing and digital I/O interface for the PC. Two Advanced Micro Devices (AMD) Am9513A System Timing Controllers (STCs) are used for the timing interface. With these chips, which feature many different timing and counting modes, the PC-TIO-10 can perform a wide range of pulse measurement and wave generation functions. A Motorola MC6821 Peripheral Interface Adapter (PIA) is used for the digital I/O interface; each of the two 8-bit I/O ports is bit-configurable. In addition, the PC-TIO-10 has two edge-sensitive interrupt inputs with programmable edge selection. Any external transistor-transistor logic (TTL) signal, including any of the counter outputs, can be connected to these interrupt inputs.

This manual describes installation, theory of operation, and basic programming considerations for the PC-TIO-10. The example programs included are written in C and assembly language.

Organization of This Manual

This manual is divided into the following chapters and appendixes:

- Chapter 1, *Introduction*, describes the PC-TIO-10, lists the contents of your PC-TIO-10 kit, lists the optional software and equipment for use with the PC-TIO-10, and explains how to unpack the PC-TIO-10 kit.
- Chapter 2, *Configuration and Installation*, describes the PC-TIO-10 jumper configurations, installation of the PC-TIO-10 board in your computer, signal connections to the PC-TIO-10 board, and cabling instructions.
- Chapter 3, *Theory of Operation*, explains the basic operation of the PC-TIO-10 circuitry.
- Chapter 4, *Programming*, describes in detail the address and function of each of the PC-TIO-10 control and status registers. This chapter also includes important information about programming the PC-TIO-10.
- Appendix A, *Specifications*, lists the specifications of the PC-TIO-10.
- Appendix B, *I/O Connector*, describes the pinout and signal names for the I/O connector on the PC-TIO-10.
- Appendix C, *AMD Am9513A Data Sheet*, contains the manufacturer data sheet for the AMD Am9513A integrated circuit. This circuit is used on the PC-TIO-10 board.
- Appendix D, *Motorola MC6821 Data Sheet*, contains the manufacturer data sheet for the Motorola MC6821 integrated circuit. This circuit is used on the PC-TIO-10 board.
- Appendix E, *Switch Settings*, lists the possible switch settings, the corresponding base I/O address, and the base I/O address space used for that setting.

- Appendix F, *Customer Communication*, contains forms for you to complete to facilitate communication with National Instruments concerning our products.
- The *Index* alphabetically lists topics covered in this manual, including the page where the topic can be found.

Conventions Used in This Manual

The following conventions are used throughout this manual:

<i>italic</i>	Italic text denotes emphasis, a cross reference, or an introduction to a key concept.
monospace	Lowercase text in this font denotes text or characters that are to be literally input from the keyboard, sections of code, programming examples, and syntax examples. This font is also used for the proper names of disk drives, paths, directories, programs, subprograms, subroutines, device names, functions, variables, filenames, and extensions, and for statements and comments taken from program code.
NI-DAQ	NI-DAQ is used throughout this manual to refer to the NI-DAQ software for DOS/Windows/LabWindows unless otherwise noted.
PC	PC refers to the IBM PC/XT, the IBM PC AT, and compatible computers, as well as EISA personal computers.

Abbreviations

The following metric system prefixes are used with abbreviations for units of measure:

Prefix	Meaning	Value
n-	nano-	10^{-9}
μ -	micro-	10^{-6}
m-	milli-	10^{-3}
k-	kilo-	10^3
M-	mega-	10^6

The following accepted abbreviations are used in this manual:

A	amperes
C	Celsius
°	degrees
hex	hexadecimal
Hz	hertz

Abbreviations (continued)

in.	inches
I_{out}	output current
m	meters
%	percent
sec	seconds
V	volts
V_{EXT}	external volt
V_{IH}	volts, input high
V_{IL}	volts, input low
V_{in}	volts in

Acronyms

The following acronyms are used in this manual:

AMD	Advanced Micro Devices
AWG	American Wire Gauge
BCD	binary-coded decimal
DMA	direct memory access
EISA	Extended Industry Standard Architecture
FSK	frequency shift keying
ISA	Industry Standard Architecture
LSB	least significant bit
MSB	most significant bit
PIA	Peripheral Interface Adapter
STC	System Timing Controller
TTL	transistor-transistor logic
VDC	volts direct current

Related Documentation

The following documents contain information that you may find helpful as you read this manual:

- *Am9513A/Am9513 System Timing Controller* technical manual
- *IBM Personal Computer XT Technical Reference* manual

Customer Communication

National Instruments wants to receive your comments on our products and manuals. We are interested in the applications you develop with our products, and we want to help if you have problems with them. To make it easy for you to contact us, this manual contains comment and configuration forms for you to complete. These forms are in Appendix B, *Customer Communication*, at the end of this manual.

Contents

Chapter 1

Introduction	1-1
What Your Kit Should Contain	1-2
Optional Software	1-3
Optional Equipment	1-3
Unpacking	1-4

Chapter 2

Configuration and Installation	2-1
Board Configuration	2-1
Base I/O Address Settings	2-2
Interrupt Level Selection	2-4
Local Interrupt Selection	2-5
Installation	2-6
Signal Connections	2-6
I/O Connector Pin Description	2-6
Signal Connection Descriptions	2-8
Timing Signal Connections	2-9
Digital I/O Signal Connections	2-13
Power Connections	2-15
Cabling	2-15

Chapter 3

Theory of Operation	3-1
Data Transceivers	3-2
PC I/O Channel Control Circuitry	3-2
Am9513A System Timing Controller	3-2
MC6821 Peripheral Interface Adapter	3-2
Interrupt Control Circuitry	3-2
Timing and Digital I/O Connector	3-3

Chapter 4

Programming	4-1
Introduction	4-1
Register Map	4-2
Register Descriptions	4-2
Register Descriptions for the Am9513A STCs	4-3
Am9513A Data Registers	4-4
Am9513A Command Registers	4-5
Am9513A Status Registers	4-6
Register Descriptions for the MC6821	4-7
MC6821 Data Registers	4-8
MC6821 Control Registers	4-9
Programming Considerations for the Am9513A STCs	4-10

Programming Example for the Am9513A STCs	4-10
Interrupt Programming Example for the MC6821	4-13
Appendix A	
Specifications	A-1
I/O Connector Electrical Specifications	A-1
I/O Signal Ratings	A-1
Input Signal Specifications	A-1
Output Signal Specifications	A-1
Operating Environment	A-2
Storage Environment	A-2
Physical Specifications	A-2
Power Requirement (from PC I/O Channel)	A-2
Appendix B	
I/O Connector	B-1
Appendix C	
AMD Am9513A Data Sheet	C-1
Appendix D	
Motorola MC6821 Data Sheet	D-1
Appendix E	
Switch Settings	E-1
Appendix F	
Customer Communication	F-1
Index	Index-1

Figures

Figure 1-1. PC-TIO-10 Interface Board	1-1
Figure 2-1. PC-TIO-10 Parts Locator Diagram	2-2
Figure 2-2. Example Base I/O Address Switch Settings	2-3
Figure 2-3. Interrupt Jumper Setting for IRQ5 (Factory Setting)	2-4
Figure 2-4. Interrupt Jumper Setting for Disabling Interrupts	2-5
Figure 2-5. Local Interrupt Jumper Setting (Factory Setting)	2-5
Figure 2-6. PC-TIO-10 I/O Connector Pin Assignments	2-7
Figure 2-7. Event-Counting Application with External Switch Gating	2-10
Figure 2-8. Frequency Measurement Application	2-11
Figure 2-9. Timing Signal Relationships	2-12
Figure 2-10. Digital I/O Connections	2-14
Figure 3-1. PC-TIO-10 Block Diagram	3-1
Figure B-1. PC-TIO-10 I/O Connector	B-1

Tables

Table 2-1.	PC-TIO-10 Factory-Set Switch and Jumper Settings	2-1
Table 2-2.	Default Settings of National Instruments Products for the PC	2-4
Table 4-1.	PC-TIO-10 Address Map	4-2
Table E-1.	Switch Settings with Corresponding Base I/O Address and Base I/O Address Space	E-1

Chapter 1

Introduction

This chapter describes the PC-TIO-10, lists the contents of your PC-TIO-10 kit, lists the optional software and equipment for use with the PC-TIO-10, and explains how to unpack the PC-TIO-10 kit.

The PC-TIO-10 is a timing and digital I/O interface for the PC. Two AMD Am9513A STCs are used for the timing interface. With these chips, which feature many different timing and counting modes, the PC-TIO-10 can perform a wide range of pulse measurement and wave generation functions. A Motorola MC6821 PIA is used for the digital I/O interface; each of the two 8-bit I/O ports is bit-configurable. In addition, the PC-TIO-10 has two edge-sensitive interrupt inputs with programmable edge selection. Any external TTL signal, including any of the counter outputs, can be connected to these interrupt inputs.

Figure 1-1 shows the PC-TIO-10 interface board.

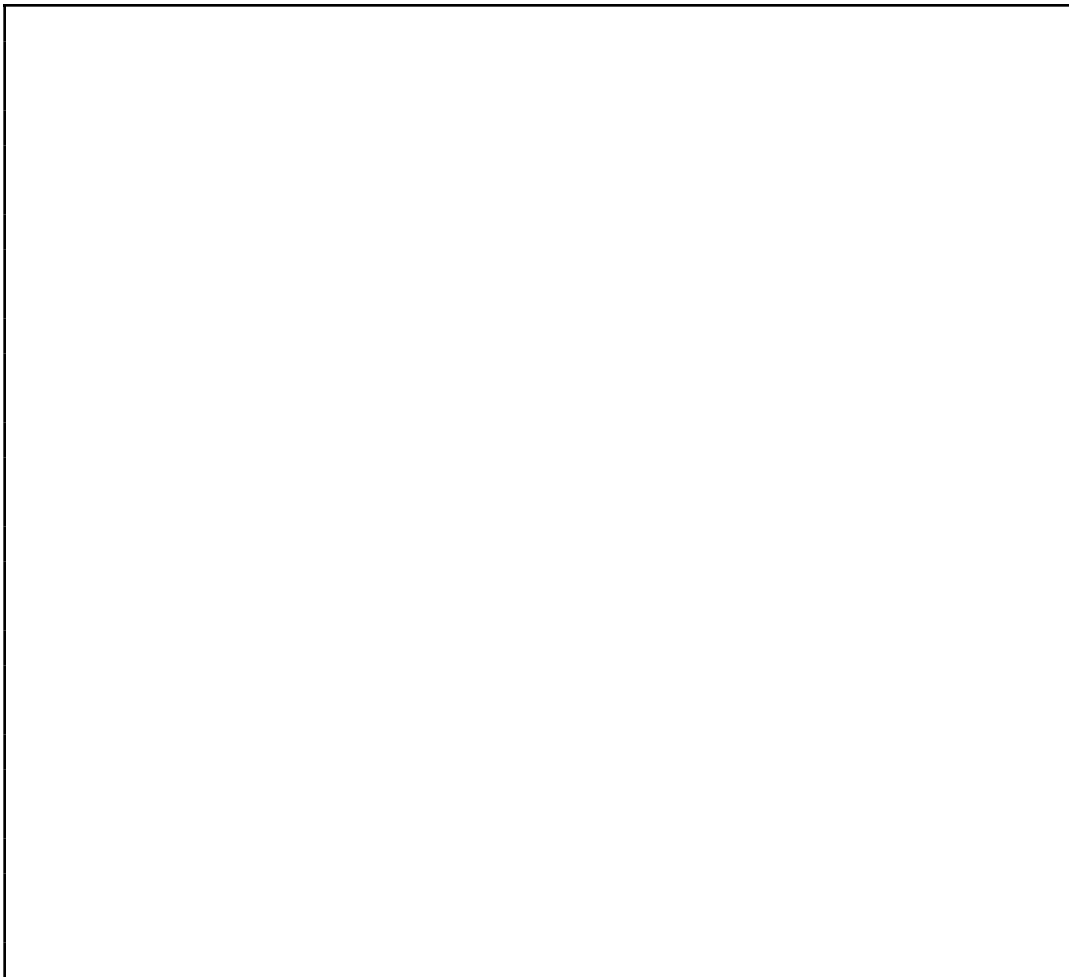

Figure 1-1. PC-TIO-10 Interface Board

The timing circuits on the board make the PC-TIO-10 useful for the following operations:

- Wave and pulse generation
- Frequency shift keying (FSK)
- Pulse-width measurement
- Time-of-day counting and alarm generation
- Event counting

The digital I/O lines on the PC-TIO-10 interface the PC to the following:

- BCD-compatible panel meters and test equipment
- Opto-isolated, solid-state relays and I/O module mounting racks

The PC-TIO-10 turns the PC into a timing and digital I/O system controller for applications in laboratory testing, production testing, and industrial process monitoring and control.

What Your Kit Should Contain

The contents of the PC-TIO-10 kit (part number 776452-01) are listed as follows.

Kit Component	Part Number
PC-TIO-10 board	181195-01
<i>PC-TIO-10 User Manual</i>	320292-01
NI-DAQ software for DOS/Windows/LabWindows, with manuals	776250-01
<i>NI-DAQ Software Reference Manual for DOS/Windows/LabWindows</i>	320498-01
<i>NI-DAQ Function Reference Manual for DOS/Windows/LabWindows</i>	320499-01

If your kit is missing any of the components, contact National Instruments.

Your PC-TIO-10 is shipped with the NI-DAQ software for DOS/Windows/LabWindows. NI-DAQ has a library of functions that can be called from your application programming environment. These functions include routines for analog input (A/D conversion), buffered data acquisition (high-speed A/D conversion), analog output (D/A conversion), waveform generation, digital I/O, counter/timer, SCXI, RTSI, and self-calibration. NI-DAQ maintains a consistent software interface among its different versions so you can switch between platforms with minimal modifications to your code. NI-DAQ comes with language interfaces for Professional BASIC, Turbo Pascal, Turbo C, Turbo C++, Borland C++, and Microsoft C for DOS; and Visual Basic, Turbo Pascal, Microsoft C with SDK, and Borland C++ for Windows. NI-DAQ software is on high-density 5.25 in. and 3.5 in. diskettes.

Optional Software

This manual contains complete instructions for directly programming the PC-TIO-10. Normally, however, you should not need to read the low-level programming details in the user manual because the NI-DAQ software package for controlling the PC-TIO-10 is included with the board. Using NI-DAQ is quicker and easier than and as flexible as using the low-level programming described in Chapter 4, *Programming*.

You can use the PC-TIO-10 with LabVIEW for Windows or LabWindows for DOS. LabVIEW and LabWindows are innovative program development software packages for data acquisition and control applications. LabVIEW uses graphical programming, whereas LabWindows enhances Microsoft C and QuickBASIC. Both packages include extensive libraries for data acquisition, instrument control, data analysis, and graphical data presentation.

Part numbers for these software packages are listed in the following table.

Software	Part Number
LabVIEW for Windows	776670-01
LabWindows	
Standard package	776473-01
Advanced Analysis Library	776474-01
Standard package with the Advanced Analysis Library	776475-01

Optional Equipment

Equipment	Part Number
CB-50 I/O connector block – 0.5 m cable	776164-01
CB-50 I/O connector block – 1.0 m cable	776164-02
Standard ribbon cable – 0.5 m	180524-05
Standard ribbon cable – 1.0 m	180524-10
Shielded ribbon cable – 0.5 m	180554-05
Shielded ribbon cable – 1.0 m	180554-10

Refer to the *Cabling* section in Chapter 2 for additional information on cabling and connectors.

Unpacking

Your PC-TIO-10 board is shipped in an antistatic package to prevent electrostatic damage to the board. Several components on the board can be damaged by electrostatic discharge. To avoid such damage in handling the board, take the following precautions:

- Touch the antistatic package to a metal part of your computer chassis before removing the board from the package.
- Remove the board from the package and inspect the board for loose components or any other sign of damage. Notify National Instruments if the board appears damaged in any way. *Do not* install a damaged board into your computer.

Chapter 2

Configuration and Installation

This chapter describes the PC-TIO-10 jumper configurations, installation of the PC-TIO-10 board in your computer, signal connections to the PC-TIO-10 board, and cabling instructions.

Board Configuration

The PC-TIO-10 contains one DIP switch and two jumpers to configure the base I/O address and interrupts, respectively. The DIP switch and jumpers are shown in the parts locator diagram in Figure 2-1.

The PC-TIO-10 is configured at the factory to a base I/O address of hex 1A0, to interrupt level 5, and to local interrupt setting No Connect and No Connect. These settings (shown in Table 2-1) are suitable for most systems. However, if your system has other hardware at this base I/O address or interrupt level, you need to change these settings on the PC-TIO-10 (as described in the following pages) or on the other hardware. Record your settings in the *PC-TIO-10 Hardware and Software Configuration Form* in Appendix F, *Customer Communication*.

Table 2-1. PC-TIO-10 Factory-Set Switch and Jumper Settings

Base I/O Address	Hex 1A0 (factory setting)	 <p>(The black side indicates the side of the switch that is pushed down.)</p>
Interrupt Level	Interrupt level 5 selected (factory setting)	W1: Row 5
Local Interrupt	No Connect and No Connect (factory setting)	W2: No Connect No Connect



Figure 2-1. PC-TIO-10 Parts Locator Diagram

Base I/O Address Settings

The base I/O address for the PC-TIO-10 is determined by the switches at position U12 (see Figure 2-1). The switches are set at the factory for the I/O address hex 1A0. With this default setting, the PC-TIO-10 uses the I/O address space hex 1A0 through 1A7.

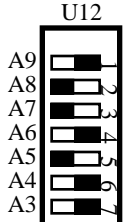
Note: Verify that this space is not already used by other equipment installed in your computer. If any equipment in your computer uses this I/O address space, you must change the base I/O address for the PC-TIO-10 or for the other device.

Each switch in U12 corresponds to one of the address lines A9 through A3. Thus, the range for possible base I/O address settings is hex 000 through 3F8. Base I/O address values hex 000 through 0FF are reserved for system use. Base I/O values hex 100 through 3FF are available on the I/O channel. A2, A1, and A0 are used by the PC-TIO-10 to decode accesses to the onboard registers. On the U12 DIP switches, press the side marked OFF to select a binary value of 1 for the corresponding address bit. Press the other side of the switch to select a binary value of 0 for the corresponding address bit. Figure 2-2 shows two possible switch settings. The black side indicates the side of the switch that is pushed down.

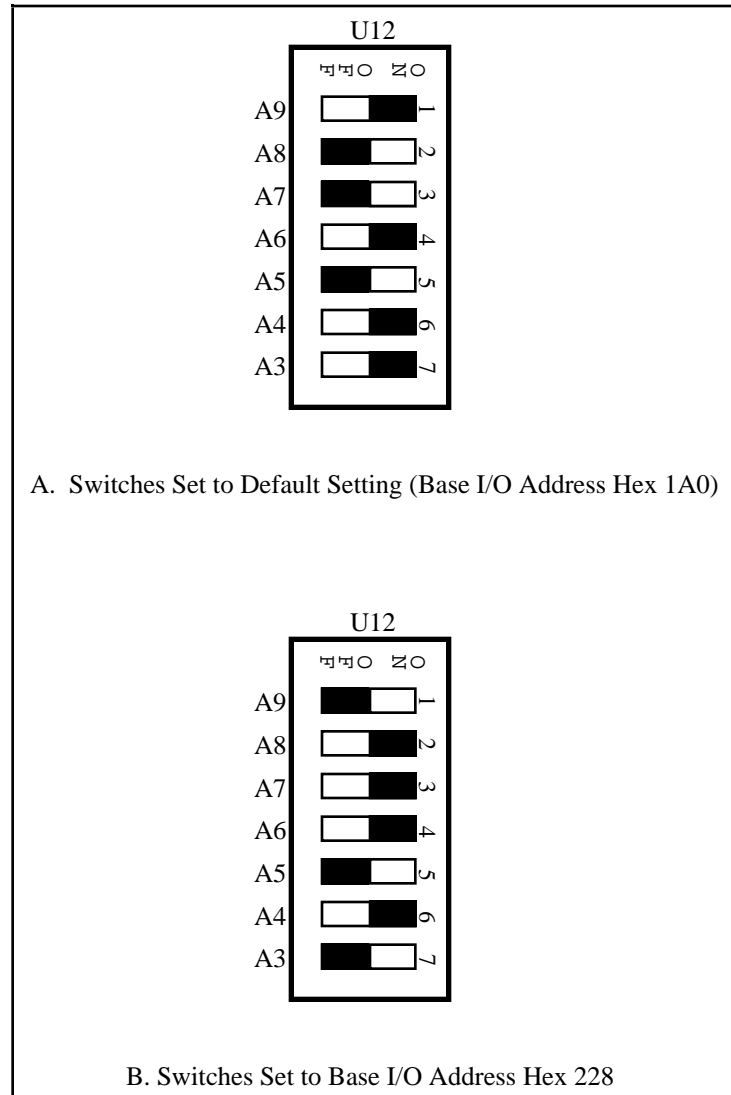

Figure 2-2. Example Base I/O Address Switch Settings

Table 2-2. Default Settings of National Instruments Products for the PC

Board	DMA Channel	Interrupt Level	Base I/O Address
AT-A2150	None*	None*	120 hex
AT-AO-6/10	Channel 5	Lines 11, 12	1C0 hex
AT-DIO-32F	Channels 5, 6	Lines 11, 12	240 hex
AT-DSP2200	None*	None*	120 hex
AT-GPIB	Channel 5	Line 11	2C0 hex
AT-MIO-16	Channels 6, 7	Line 10	220 hex
AT-MIO-16D	Channels 6, 7	Lines 5, 10	220 hex
AT-MIO-16F-5	Channels 6, 7	Line 10	220 hex
AT-MIO-16X	None*	None*	220 hex
AT-MIO-64F-5	None*	None*	220 hex
GPIB-PCII	Channel 1	Line 7	2B8 hex
GPIB-PCIIA	Channel 1	Line 7	02E1 hex
GPIB-PCIII	Channel 1	Line 7	280 hex
Lab-PC	Channel 3	Line 5	260 hex
PC-DIO-24	None	Line 5	210 hex
PC-DIO-96	None	Line 5	180 hex
PC-LPM-16	None	Line 5	260 hex
PC-TIO-10	None	Line 5	1A0 hex

* These settings are software configurable and are disabled at startup time.

Interrupt Level Selection

There are two sets of jumpers for interrupt selection on the PC-TIO-10 board. W1 is used for selecting the interrupt level, while W2 is used for local selection of two of the counter outputs as interrupt sources. The locations of these jumpers are shown in Figure 2-1.

The PC-TIO-10 board can connect to any one of six interrupt lines of the PC I/O Channel: IRQ3, IRQ4, IRQ5, IRQ6, IRQ7, or IRQ9. You select the interrupt line by setting a jumper on W1. The default interrupt line is IRQ5. To change to another line, remove the jumper from IRQ5 and place it on the pins for another request line. Figure 2-3 shows the default factory setting for IRQ5.

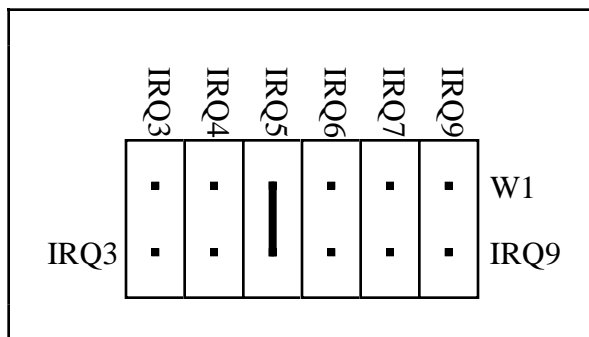

Figure 2-3. Interrupt Jumper Setting for IRQ5 (Factory Setting)

To disable the PC-TIO-10 interrupt request line, change the jumper setting as shown in Figure 2-4.

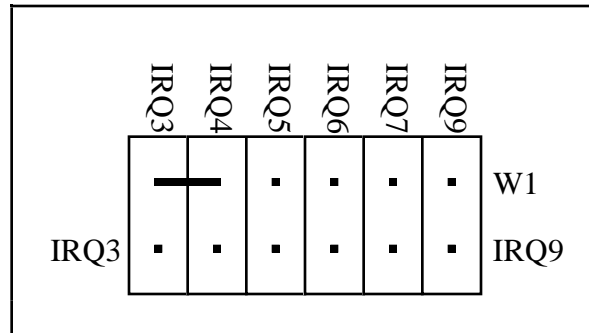

Figure 2-4. Interrupt Jumper Setting for Disabling Interrupts

Local Interrupt Selection

In addition to the jumpers for selecting the interrupt level used by the PC-TIO-10, a set of jumpers, W2, is used to locally connect two of the counter outputs to the interrupt generation circuitry. There are four positions on this set of jumpers: two No Connect positions (labelled N.C.), a position for OUT2, and a position for OUT7. The position for OUT2 connects the output of Counter 2 to the EXTIRQ1 input, while the position for OUT7 connects the output of Counter 7 to the EXTIRQ2 input. The No Connect positions are intended as storage positions for one or both of the jumpers if you do not want to use one or both of the counter outputs for interrupt purposes. The default positions for the jumpers on W2 are shown in Figure 2-5.

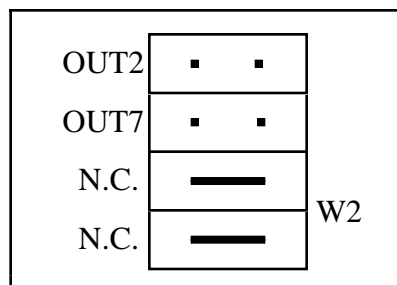

Figure 2-5. Local Interrupt Jumper Setting (Factory Setting)

OUT2 and OUT7 can be jumpered simultaneously. The interrupt for OUT2 is enabled and disabled through access to the Port A interrupt-control circuitry of the MC6821 PIA. OUT7 is enabled and disabled through access to the Port B interrupt-control circuitry of the MC6821 PIA. One or both of these interrupts can be asserted at any time (if they are enabled). If both interrupts are enabled simultaneously, your interrupt handler must check both channels for interrupts before returning control to the foreground task. For more information, see Chapter 4, *Programming*.

Installation

The PC-TIO-10 can be installed in any unused 8-bit, 16-bit, or 32-bit expansion slot in your computer. After you make any necessary changes and verify the switch and jumper settings, record them in the *PC-TIO-10 Hardware and Software Configuration Form* in Appendix F, *Customer Communication*. You are now ready to install the PC-TIO-10.

The following are general installation instructions, but consult the user manual or technical reference manual of your personal computer for specific instructions and warnings. If you want to install this board in an EISA-class computer, you can obtain a configuration file for the board by contacting National Instruments.

1. Turn off your computer.
2. Remove the top cover or access port to the I/O channel.
3. Remove the expansion slot cover on the back panel of the computer.
4. Insert the PC-TIO-10 in an unused 8-bit, 16-bit, or 32-bit slot. It may be a tight fit, but *do not* force the board into place.
5. Screw the mounting bracket of the PC-TIO-10 to the back panel rail of the computer.
6. Check the installation.
7. Replace the cover to the computer.

Note: If you have an ISA-class computer and you are using a configurable software package, such as NI-DAQ, you may need to reconfigure your software to reflect any changes in jumper or switch settings. If you have an EISA-class computer, you need to update the computer's resource allocation (or configuration) table by reconfiguring your computer. See your computer's user manual for information about updating the configuration table.

The PC-TIO-10 board is now installed and ready for operation.

Signal Connections

This section includes specifications and connection instructions for the signals given on the PC-TIO-10 I/O connector.

Warning: Connections that exceed any of the maximum ratings of input or output signals on the PC-TIO-10 may result in damage to the PC-TIO-10 board and to the PC. Maximum input ratings for each signal are given in this chapter under the discussion of that signal. National Instruments is not liable for any damages resulting from any such signal connections.

I/O Connector Pin Description

Figure 2-6 show the pin assignments for the PC-TIO-10 I/O connector.

SOURCE1	1	2	GATE1
OUT1	3	4	SOURCE2
GATE2	5	6	OUT2
SOURCE3	7	8	GATE3
OUT3	9	10	SOURCE4
GATE4	11	12	OUT4
GATE5	13	14	OUT5
SOURCE6	15	16	GATE6
OUT6	17	18	SOURCE7
GATE7	19	20	OUT7
SOURCE8	21	22	GATE8
OUT8	23	24	SOURCE9
GATE9	25	26	OUT9
GATE10	27	28	OUT10
FOUT1	29	30	FOUT2
EXTIRQ1	31	32	EXTIRQ2
GND	33	34	+5 V
A0	35	36	A1
A2	37	38	A3
A4	39	40	A5
A6	41	42	A7
B0	43	44	B1
B2	45	46	B3
B4	47	48	B5
B6	49	50	B7

Figure 2-6. PC-TIO-10 I/O Connector Pin Assignments

Signal Connection Descriptions

Pins	Signal Names	Description
1, 4, 7, 10, 15, 18, 21, 24	SOURCE<1..4> SOURCE<6..9>	These are the source inputs for Counters 1 through 4 and Counters 6 through 9. The source inputs for Counters 5 and 10 do not appear on the I/O connector because they are internally connected to a 5-MHz clock.
2, 5, 8, 11, 13, 16, 19, 22, 25, 27	GATE<1..10>	These are the gate inputs for Counters 1 through 10.
3, 6, 9, 12, 14, 17, 20, 23, 26, 28	OUT<1..10>	These are the outputs for Counters 1 through 10.
29-30	FOUT<1..2>	These are the frequency outputs of the two Am9513A devices.
31-32	EXTIRQ<1..2>	These are the interrupt inputs for the PC-TIO-10.
33	GND	This pin is connected to the computer's ground signal.
34	+5 V	This pin is connected to the computer's +5 VDC power supply.
35-42 A	A<0..7>	These are the eight digital I/O lines on Port of the MC6821. The MSB is A7.
43-50 B	B<0..7>	These are the eight digital I/O lines on Port of the MC6821. The MSB is B7.

Timing Signal Connections

Pins 1 through 30 of the I/O connector are connections for timing I/O signals on the two onboard Am9513A Counter/Timers. The timing signals include the GATE, SOURCE, and OUT signals for the Am9513A Counters 1 through 10, and the FOUT1 and FOUT2 signals generated by the Am9513A STCs. Counters 1 through 10 of the Am9513A Counter/Timers can be used for general-purpose applications, such as pulse and square wave generation, event counting, and pulse-width, time-lapse, and frequency measurements. For these applications, SOURCE and GATE signals can be directly applied to the counters from the I/O connector, and the counters are programmed for various operations.

The Am9513A Counter/Timer is described briefly in Chapter 3, *Theory of Operation*. For detailed programming information, consult Appendix C, *AMD Am9513A Data Sheet*. For detailed applications information, consult the *Am9513A/Am9513A System Timing Controller* technical manual published by Advanced Micro Devices, Inc.

Pulses and square waves can be produced by programming a counter to generate a pulse signal at its OUT pin or to toggle the OUT signal each time the counter reaches the terminal count.

For event counting, one of the counters is programmed to count rising or falling edges applied to any of the Am9513A SOURCE inputs. The counter value can then be read to determine the number of edges that have occurred. Counter operation can be gated on and off during event counting.

Figure 2-7 shows connections for a typical event-counting operation where a switch is used to gate the counter on and off.

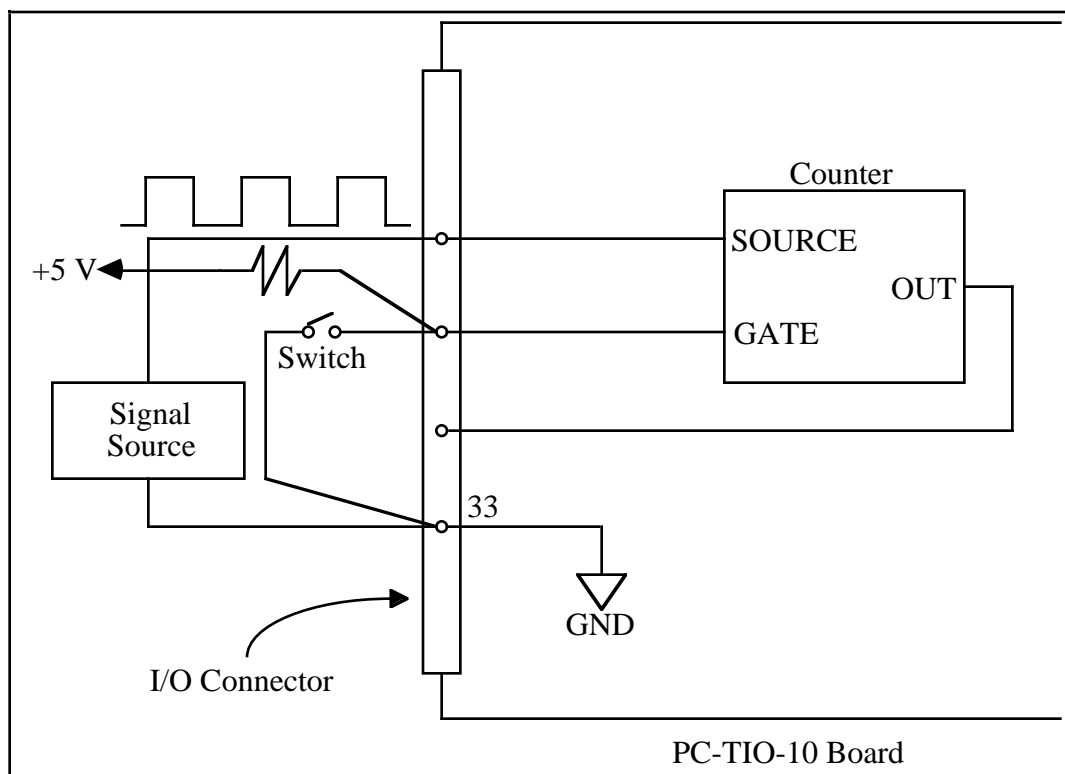

Figure 2-7. Event-Counting Application with External Switch Gating

To perform pulse-width measurement, a counter is programmed to be level-gated. The pulse to be measured is applied to the counter GATE input. The counter is programmed to count while the signal at the GATE input is either high or low. If the counter is programmed to count an internal timebase, then the pulse width is equal to the counter value multiplied by the timebase period.

For time-lapse measurement, a counter is programmed to be edge-gated. An edge is applied to the counter GATE input to start the counter. The counter can be programmed to start counting after receiving either a high-to-low edge or a low-to-high edge. If the counter is programmed to count an internal timebase, then the time lapse since receiving the edge is equal to the counter value multiplied by the timebase period.

To measure frequency, a counter is programmed to be level-gated and the rising or falling edges are counted in a signal applied to a SOURCE input. The gate signal applied to the counter GATE input is of some known duration. In this case, the counter is programmed to count either rising or falling edges at the SOURCE input while the gate is applied. The frequency of the input signal is then the count value divided by the known gate period. Figure 2-8 shows the connections for a frequency measurement application. A second counter can also be used to generate the gate signal in this application.

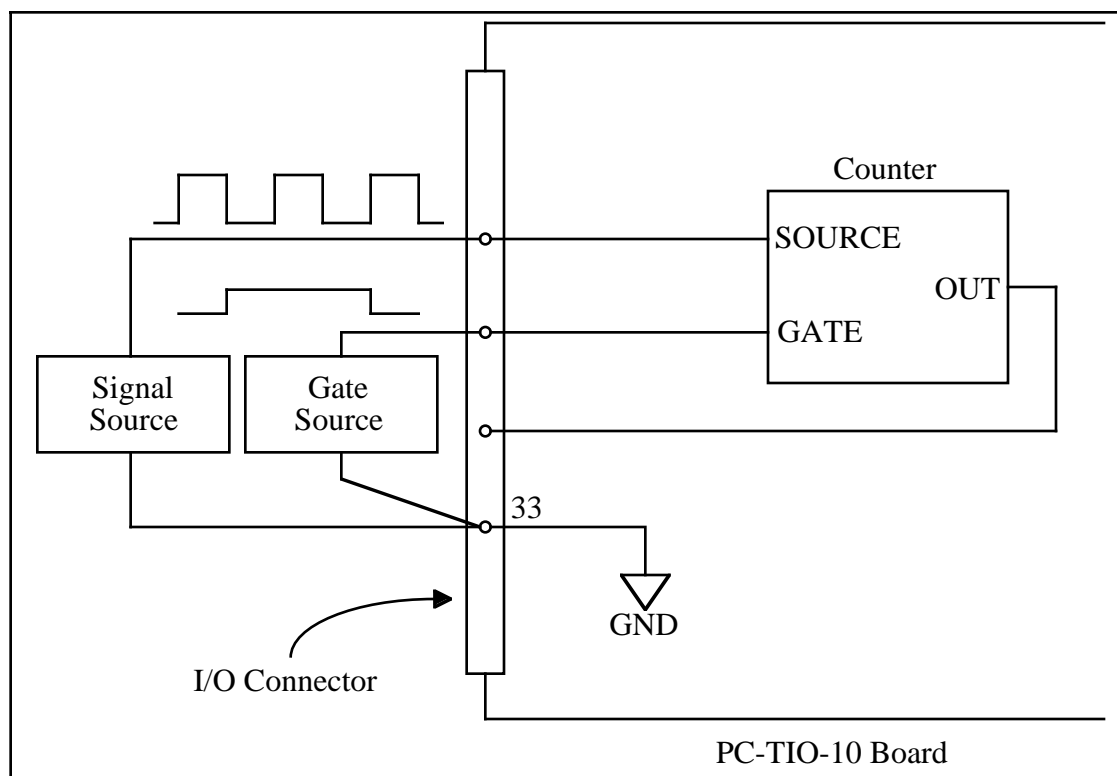

Figure 2-8. Frequency Measurement Application

Two or more counters can be concatenated by connecting the OUT signal from one counter to the SOURCE signal of another counter. The counters can then be treated as one 32-bit or larger counter for most counting applications. It is possible to create up to a 160-bit counter in this manner.

The GATE, SOURCE, OUT, and FOUT signals on the I/O connector are connected directly to the Am9513A input and output pins. The input and output ratings and timing specifications for the Am9513A signals are given as follows.

The following specifications and ratings apply to the Am9513A I/O signals.

Absolute maximum voltage rating -0.5 to +7.0 V with respect to GND

Am9513A Digital Input Specifications (referenced to GND):

	Minimum	Maximum
Input logic high voltage	2.0 V	5.25 V
Input logic low voltage	0.0 V	0.8 V
Input current ($0 < V_{in} < 5.25$ V)	-10 μ A	10 μ A

Am9513A Digital Output Specifications (referenced to GND):

	Minimum	Maximum
Output logic high voltage, all outputs at $I_{out} = -200 \mu A$	2.4 V	5.0 V
Output logic low voltage, all outputs at $I_{out} = 3.2 \text{ mA}$	0.0 V	0.4 V

Figure 2-9 shows the timing requirements for the GATE and SOURCE input signals and the timing specifications for the OUT signals of the Am9513A STCs.

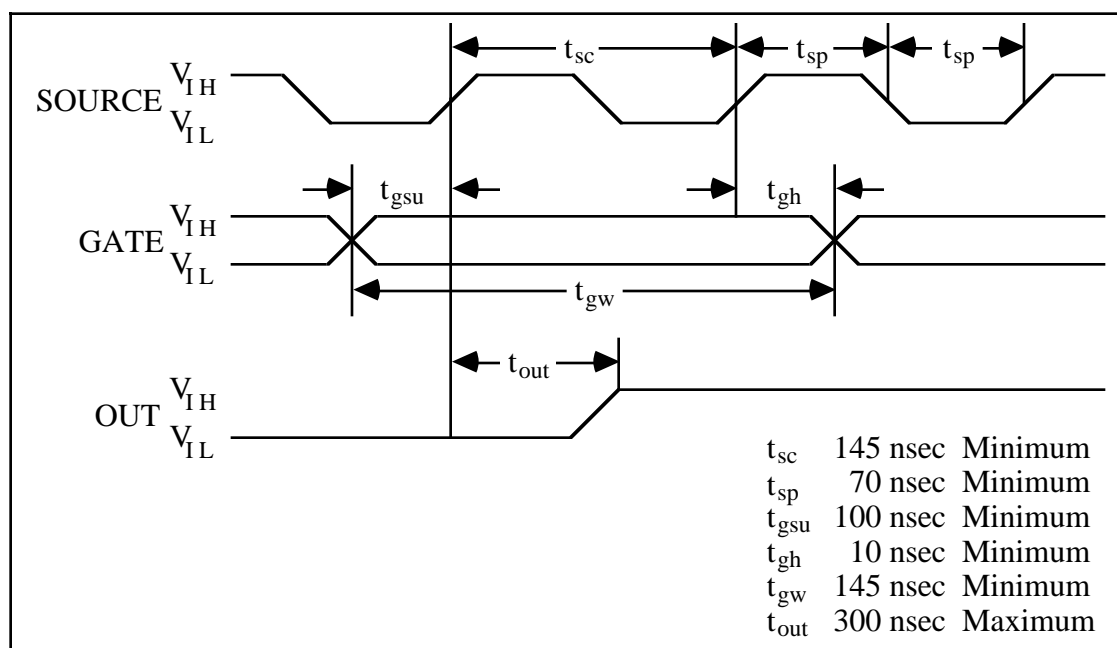

Figure 2-9. Timing Signal Relationships

The GATE and OUT signal transitions in Figure 2-9 are referenced to the rising edge of the SOURCE signal. This timing diagram assumes that the counters are programmed to count rising edges. The same timing diagram, with the source signal inverted and referenced to the falling edge of the source signal, applies to the case in which the counter is programmed to count falling edges.

The signal applied at a SOURCE input can be used as a clock source by any of the Am9513A counter/timers and by the Am9513A frequency division output FOUT. The signal applied to a SOURCE input must not exceed a frequency of 7 MHz for proper operation of the Am9513A. The Am9513A counters can be individually programmed to count rising or falling edges of signals applied at any of the Am9513A SOURCE or GATE input pins.

In addition to the signals applied to the SOURCE and GATE inputs, the Am9513A generates five internal timebase clocks from the clock signal supplied by the PC-TIO-10. The five internal

timebase clocks can be used as counting sources, and these clocks have a maximum skew of 75 nsec between them. The SOURCE signal shown in Figure 2-9 represents any of the signals applied at the SOURCE inputs, GATE inputs, or internal timebase clocks. See the Am9513A data sheet in Appendix C for further details.

Specifications for signals at the GATE input are referenced to the signal at the SOURCE input or one of the Am9513A internally generated signals. Figure 2-9 shows the GATE signal referenced to the rising edge of a source signal. The gate must be valid (either high or low) at least 100 nsec before the rising or falling edge of a source signal for the gate to take effect at that source edge (as shown by t_{gsu} and t_{gh} in Figure 2-9). Similarly, the gate signal must be held for at least 10 nsec after the rising or falling edge of a source signal for the gate to take effect at that source edge. The gate high or low period must be at least 145 nsec in duration. If an internal timebase clock is used, the gate signal cannot be synchronized with the clock. In this case, gates applied close to a source edge take effect either on that source edge or on the next one. This arrangement creates an uncertainty of one source clock period with respect to unsynchronized gating sources.

Signals generated at the OUT pin are referenced to the signal at the SOURCE input or to one of the Am9513A internally generated clock signals. Figure 2-9 shows the OUT signal referenced to the rising edge of a source signal. Any OUT signal state changes occur within 300 nsec after the source signal's rising or falling edge.

Digital I/O Signal Connections

Pins 31, 32, and 35 through 50 of the I/O connector are digital I/O signal pins.

Pins 35 through 42 are connected to the digital lines A<0..7> for digital I/O Port A. Pins 43 through 50 are connected to the digital lines B<0..7> for digital I/O Port B. Pins 31 and 32 are connected to the external interrupt lines, EXTIRQ1 and EXTIRQ2. Ports A and B can be programmed on a bitwise basis to be inputs or outputs.

The following specifications and ratings apply to the digital I/O lines.

Absolute maximum voltage rating -0.3 to +7.0 V with respect to GND

Digital Input Specifications (referenced to GND):

	Minimum	Maximum
Input logic high voltage	2.0 V	5.25 V
Input logic low voltage	0.0 V	0.8 V
Input current, Port A ($0 < V_{in} < 0.8 \text{ V}$)	—	-2.4 mA
Input current, Port A ($2.0 < V_{in} < 5.25 \text{ V}$)	—	-400 μA
Input current, Port B ($0.4 < V_{in} < 2.4 \text{ V}$)	—	10 μA
Input current, EXTIRQ1 and EXTIRQ2 ($0 < V_{in} < 5.25 \text{ V}$)	—	2.5 μA

Digital Output Specifications (referenced to GND):

	Minimum	Maximum
Output logic high voltage at $I_{out} = -200 \mu A$	2.4 V	5.0 V
Output logic low voltage at $I_{out} = 3.2 \text{ mA}$	0.0 V	0.4 V
Darlington drive current, Port B at $V_{EXT} = 1.5 \text{ V}$	-1.0 mA	-10.0 mA

Figure 2-10 depicts signal connections for three typical digital I/O applications.

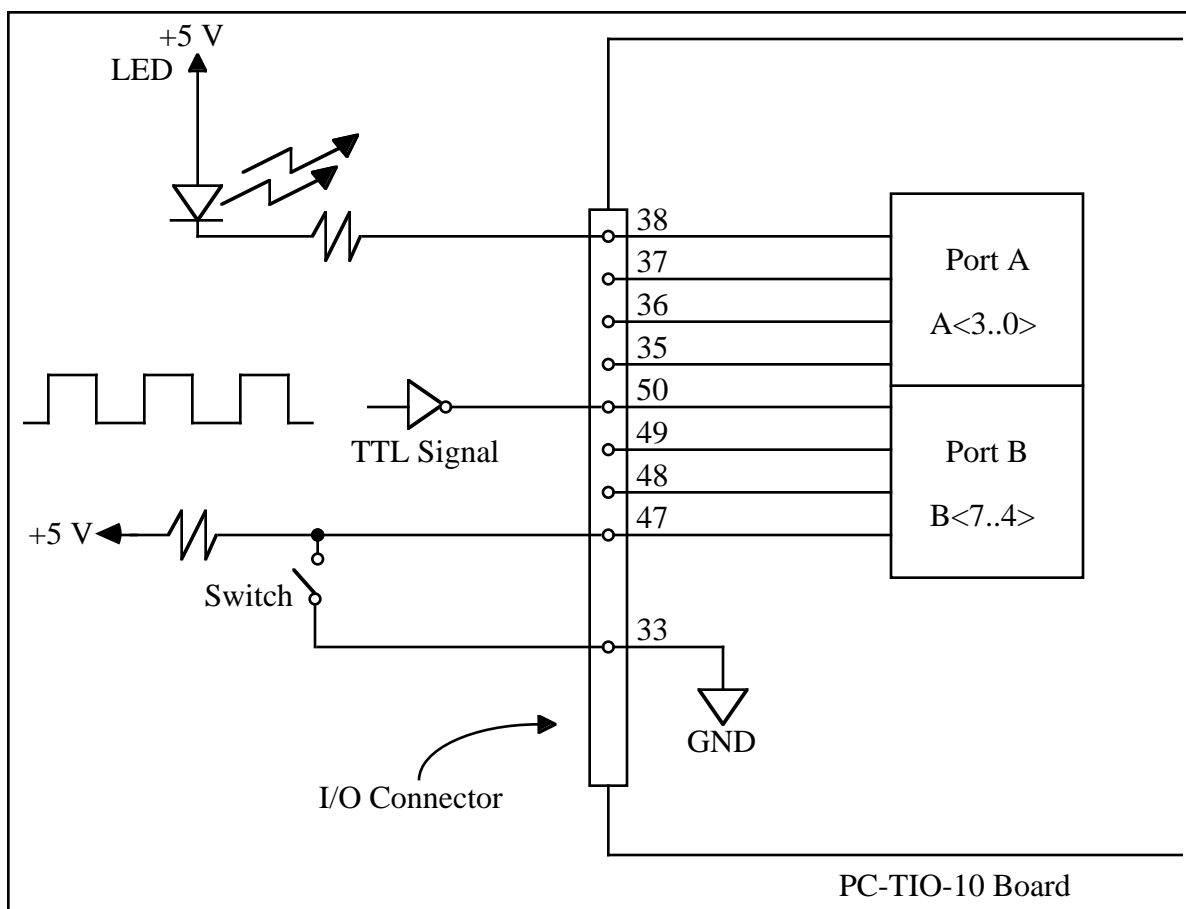

Figure 2-10. Digital I/O Connections

In Figure 2-10, Port A is configured for digital output, and Port B is configured for digital input. Digital input applications include receiving TTL signals and sensing external device states such as the state of the switch in Figure 2-10. Digital output applications include sending TTL signals and driving external devices such as the LED shown in Figure 2-10.

Power Connections

Pin 34 of the I/O connector is connected to the +5 V supply from the PC power supply. This pin is referenced to GND and can be used to power external digital circuitry. For more information on this output pin, see *Output Signal Specifications* in Appendix A, *Specifications*.

Power Rating	1.0 A at +5 V \pm 10%
--------------	-------------------------

Warning: *Under no circumstances* should this +5-V power pin be connected directly to ground or to any other voltage source on the PC-TIO-10 or any other device. Doing so may damage the PC-TIO-10 and the PC. National Instruments is not liable for damage resulting from such a connection.

Cabling

The PC-TIO-10 digital I/O connector is a standard, 50-pin, header connector, which can be interfaced using 50-pin ribbon cable with appropriate connectors. The CB-50 cable termination accessory is available from National Instruments for use with the PC-TIO-10 board. This kit includes a 50-conductor, flat ribbon cable and a connector block. Signal input and output wires can be attached to screw terminals on the connector block and are therefore connected to the PC-TIO-10 I/O connector.

The CB-50 is useful for initial prototyping of an application or in situations where PC-TIO-10 interconnections are frequently changed. Once a final field wiring scheme has been developed, however, you may want to develop your own cable. This section contains information for the design of custom cables.

The PC-TIO-10 I/O connector is a 50-pin, male, ribbon-cable header connector. The manufacturers and the appropriate part numbers for this connector are as follows:

- Electronic Products Division/3M (part number 3596-5002)
- T&B/Ansley Corporation (part number 609-5007)

The mating connector for the PC-TIO-10 is a 50-position, polarized, ribbon-socket connector with strain relief. National Instruments uses a polarized (keyed) connector to prevent inadvertent upside-down connection to the PC-TIO-10. Recommended manufacturers and the appropriate part numbers for this mating connector are as follows:

- Electronic Products Division/3M (part number 3425-7650)
- T&B/Ansley Corporation (part number 609-5041CE)

Recommended manufacturer part numbers for the standard ribbon cable (50-conductor, 28 AWG, stranded) that can be used with these connectors are as follows:

- Electronic Products Division/3M (part number 3365/50)
- T&B/Ansley Corporation (part number 171-50)

Chapter 3

Theory of Operation

This chapter explains the basic operation of the PC-TIO-10 circuitry.

The block diagram in Figure 3-1 illustrates the key functional components of the PC-TIO-10 board.

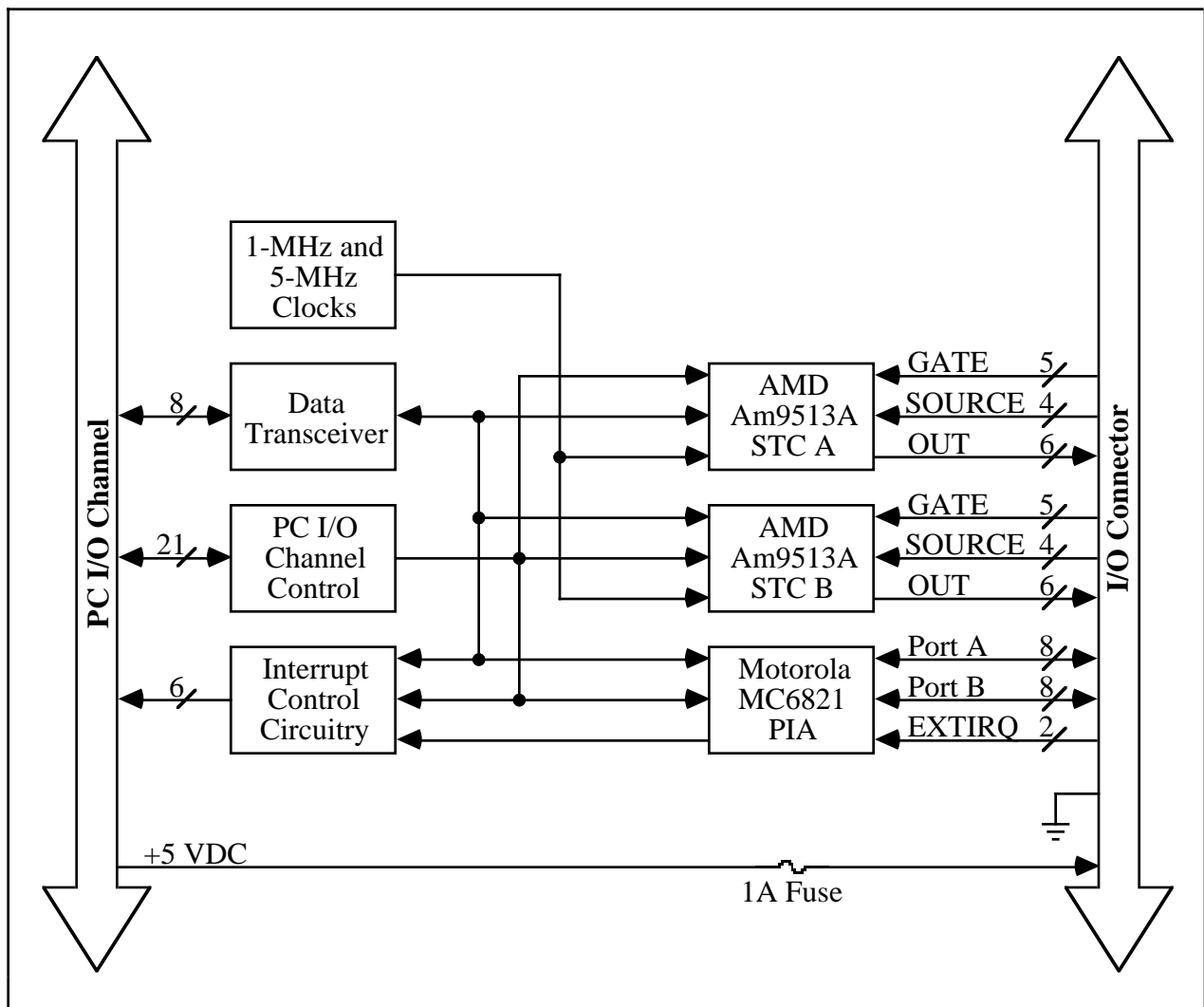

Figure 3-1. PC-TIO-10 Block Diagram

The PC I/O channel consists of an address bus, a data bus, a DMA arbitration bus, interrupt lines, and several control and support signals.

Data Transceivers

The data transceivers control the sending and receiving of data to and from the PC I/O Channel.

PC I/O Channel Control Circuitry

The base address used by the board is determined by an onboard switch setting. The address on the PC I/O channel bus is monitored by the address decoder, which is part of the I/O channel control circuitry. If the address on the bus matches the selected I/O base address of the board, the board is enabled and the corresponding register on the PC-TIO-10 is accessed.

In addition, the I/O channel control circuitry monitors and transmits the PC I/O channel control and support signals. The control signals identify transfers as read or write, memory or I/O, and 8-bit, 16-bit, or 32-bit transfers. The PC-TIO-10 uses only 8-bit transfers.

Am9513A System Timing Controller

The Am9513A STCs are the heart of the PC-TIO-10. These chips have five individually-controlled 16-bit counters, each of which can be configured to operate in a number of different modes. Therefore, the PC-TIO-10 can be used for applications such as rate generation, FSK, and pulse parameter measurement. Each of the counters has its own source (SOURCE), gate (GATE), and output (OUT) connections. Each STC has an independently-controlled, frequency-scaler output. The STCs are clocked by an onboard 1-MHz crystal oscillator to give 1- μ sec timing resolution. In addition, SOURCE5 and SOURCE10 are clocked at 5 MHz to give 200-nsec resolution on all timing channels. Refer to Chapter 4, *Programming*, or to Appendix C, *AMD Am9513A Data Sheet*, for more detailed information.

MC6821 Peripheral Interface Adapter

The MC6821 PIA features sixteen bits of bit-configurable digital I/O. In addition, this device has two edge-programmable interrupt inputs, with which the PC-TIO-10 can receive external interrupts. Refer to Chapter 4, *Programming*, or to Appendix D, *Motorola MC6821 Data Sheet*, for more detailed information.

Interrupt Control Circuitry

The interrupt level used by the PC-TIO-10 is selected by the onboard jumper W1. Interrupts can be generated from two different sources, EXTIRQ1 and EXTIRQ2, each of which has programmable-edge polarity and individual enable, clear, and disable commands. A second set of jumpers, W2, locally connects two of the counter outputs to the interrupt circuitry. With these connections, external wrap-backs are unnecessary if you want to use a counter to generate timed interrupts. Refer to Chapter 4, *Programming*, or to Appendix D, *Motorola MC6821 Data Sheet*, for more detailed information on controlling interrupts. Refer to Chapter 2, *Configuration and Installation*, for more information on configuring the jumper settings.

Timing and Digital I/O Connector

All timing and digital I/O is transmitted through a standard, 50-pin, male connector. Pin 34 is connected to +5 V through a protection fuse (F1). This +5 V supply is often required to operate I/O module mounting racks. Pin 33 is connected to ground. See Chapter 2, *Configuration and Installation*, for additional information.

Chapter 4

Programming

This chapter describes in detail the address and function of each of the PC-TIO-10 control and status registers. This chapter also includes important information about programming the PC-TIO-10.

The PC-TIO-10 is a timing and digital I/O board designed around two Am9513A integrated circuits and one MC6821 integrated circuit. The Am9513A is a general-purpose counter/timer with five 16-bit, individually-controlled counters and a 4-bit frequency-scaler output. The MC6821 is a 16-bit, bit-configurable, digital I/O device with two interrupt inputs that are edge-programmable. This chapter includes programming information for the PC-TIO-10, along with program examples written in C and assembly language.

Note: If you plan to use a programming software package such as LabWindows or NI-DAQ with your PC-TIO-10 board, you need not read this chapter.

Introduction

Each of the two Am9513A STC devices is controlled by three different registers—a data register, a command register, and a status register. These registers are defined later in this chapter. Because there are two Am9513A STC devices on the board, they are referenced as STC A and STC B when differentiation is required.

The MC6821 PIA has four different registers that control its operation. The 16 I/O lines are grouped into two 8-bit ports, Port A and Port B, each of which has a control register and a data register associated with it. These registers are defined later in this chapter.

For clarification, both *registers* and *ports* are referenced in the sections that follow. A *register* refers to a given 8-bit or 16-bit register on the actual Am9513A STC or MC6821 PIA, whereas a *port* refers to the I/O channel register through which the device must be accessed. Therefore, the size shown for a register indicates both the register size and the I/O channel port size. The digital I/O ports associated with the MC6821 PIA are always referenced as Port A and Port B.

Register Map

The following table lists the address map for the PC-TIO-10.

Table 4-1. PC-TIO-10 Address Map

Register	Offset Address (Hex)	Size	Type
Am9513A Register Group			
STC A			
Data Register	00	8-bit	Read-and-write
Command Register	01	8-bit	Write-only
Status Register	01	8-bit	Read-only
STC B			
Data Register	02	8-bit	Read-and-write
Command Register	03	8-bit	Write-only
Status Register	03	8-bit	Read-only
MC6821 Register Group			
PIA			
Port A Data Register	04	8-bit	Read-and-write
Port A Control Register	05	8-bit	Read-and-write
Port B Data Register	06	8-bit	Read-and-write
Port B Control Register	07	8-bit	Read-and-write

Register Descriptions

The register descriptions for the devices on the PC-TIO-10, including the Am9513A STCs and the MC6821 PIA, are given on the pages that follow.

Register Descriptions for the Am9513A STCs

Each of the two Am9513A STC devices has three registers—a data register, a command register, and a status register. The bit maps and signal definitions for each of these registers are as follows. Counters 1, 2, 3, 4, and 5 map to Counters 1, 2, 3, 4, and 5 of STC A, respectively; Counters 6, 7, 8, 9, and 10 map to Counters 1, 2, 3, 4, and 5 of STC B, respectively.

Am9513A Data Registers

The Am9513A Data Registers are used to read from or write to any of the 18 internal registers of the Am9513A. The Am9513A Command Registers must be written to in order to select the register to be accessed by the Am9513A Data Registers. The internal registers accessed by the Am9513A Data Registers are as follows:

- Counter Mode Registers for Counters 1, 2, 3, 4, and 5
- Counter Load Registers for Counters 1, 2, 3, 4, and 5
- Counter Hold Registers for Counters 1, 2, 3, 4, and 5
- Compare Registers for Counters 1 and 2
- Master Mode Register

All these registers are 16-bit registers that must be accessed through an 8-bit port, least significant byte first. Bit descriptions for each of these registers are included in Appendix C, *AMD Am9513A Data Sheet*.

Address: Base address + 00 (hex) for Am9513A STC A
 Base address + 02 (hex) for Am9513A STC B

Type: Read-and-write

Word Size: 16-bit register, 8-bit port

Bit Map:

7	6	5	4	3	2	1	0
D15	D14	D13	D12	D11	D10	D9	D8
7	6	5	4	3	2	1	0
D7	D6	D5	D4	D3	D2	D1	D0

Bit	Name	Description
7-0	D<15..8>	These eight bits are the most significant byte to be loaded into or read from the Am9513A Internal Register currently selected. These eight bits should be accessed after the eight bits of the least significant byte are accessed.
7-0	D<7..0>	These eight bits are the least significant byte to be loaded into or read from the Am9513A Internal Register currently selected. These eight bits should be accessed before the eight bits of the most significant byte are accessed.

Am9513A Command Registers

The Am9513A Command Registers control the overall operation of the Am9513A Counter/Timer and selection of the internal registers that are accessed through the Am9513A Data Registers.

Address: Base address + 01 (hex) for Am9513A STC A
Base address + 03 (hex) for Am9513A STC B

Type: Write-only

Word Size: 8-bit register, 8-bit port

Bit Map:

7	6	5	4	3	2	1	0
C7	C6	C5	C4	C3	C2	C1	C0

Bit	Name	Description
7-0	C<7..0>	These eight bits are loaded into the Am9513A Command Register. See Appendix C, <i>Am9513A Data Sheet</i> , for detailed bit descriptions of the Am9513A Command Registers.

Am9513A Status Registers

The Am9513A Status Registers give information about the output pin status of each counter in the Am9513A. In addition, these registers indicate the current setting of the byte pointer, which indicates whether the next byte to be accessed is the most significant byte or the least significant byte.

Address: Base address + 01 (hex) for Am9513A STC A
 Base address + 03 (hex) for Am9513A STC B

Type: Read-only

Word Size: 8-bit register, 8-bit port

Bit Map:

7	6	5	4	3	2	1	0
X	X	OUT5	OUT4	OUT3	OUT2	OUT1	BYTE POINTER

Bit	Name	Description
7-6	X	Unused bits. They may be returned as 0 or 1.
5-1	OUT<5..1>	Each of these five bits returns the logic state of the associated counter output pin. For example, if the bit OUT4 is set, then the output pin of Counter 4 (or Counter 9) is at a logic-high state.
0	BYTE POINTER	This bit represents the state of the Am9513A Byte Pointer Flip-Flop. If this bit is set, the next byte to be written to or read from the Data Port is the least significant byte; if this bit is clear, the next byte to be written to or read from the Data Port is the most significant byte.

Register Descriptions for the MC6821

The MC6821 PIA has four registers—Port A and Port B both have a Data Register and a Control Register. The bit maps and signal definitions for each of these registers are as follows. For more information on the various registers, refer to Appendix D, *Motorola MC6821 Data Sheet*.

MC6821 Data Registers

The MC6821 Data Registers are used to read from or write to the Output Registers (the I/O registers for Ports A and B) and the Data Direction Registers.

Address: Base address + 04 (hex) for Port A
 Base address + 06 (hex) for Port B

Type: Read-and-write

Word Size: 8-bit register, 8-bit port

Bit Map:

7	6	5	4	3	2	1	0
D7	D6	D5	D4	D3	D2	D1	D0

Bit	Name	Description
7-0	D<7..0>	If the Output Register is being accessed (see the description of the Control Registers on the page that follows), writing a value to the Data Register updates all output bits and has no effect on input bits. Reading the Data Register returns the current signal value of all bits, including those configured for output. If the Data Direction Register is being accessed, writing a zero to a bit makes the corresponding I/O line an input, while writing a one to a bit makes the corresponding I/O line an output. Reading the Data Direction Register returns the current configuration.

MC6821 Control Registers

The MC6821 Control Registers control the overall operation of the MC6821 and the selection of the two internal registers that are accessed through each of the MC6821 Data Registers. Some of the bits in the Control Registers are not used because of the design of the PC-TIO-10. These bits should be set as follows.

Address: Base address + 05 (hex) for Port A
 Base address + 07 (hex) for Port B

Type: Read-and-write

Word Size: 8-bit register, 8-bit port

Bit Map:

7	6	5	4	3	2	1	0
IRQ	0	0	0	0	DRS	EDGE	INTEN

Bit	Name	Description
7	IRQ	This is a read-only bit that reflects the current status of the interrupt input for the selected Control Register. If this bit is one in the Port A Control Register, an interrupt request is pending on the external interrupt line EXTIRQ1. If this bit is one in the Port B Control Register, an interrupt request is pending on the external interrupt line EXTIRQ2. Always write a zero to this bit.
6-3	Reserved	These bits are not used on the PC-TIO-10. <i>Always</i> write a zero to each of these bits.
2	DRS	This is the Data Register Select bit. Writing a one to this bit selects the Output Register, while writing a zero to this bit selects the Data Direction Register. Reading this bit shows the bit's current state. Refer to the description of the Data Register for more information.
1	EDGE	This is the control bit for selecting the edge that will cause an interrupt. Writing a one to this bit selects rising-edge interrupts, while writing a zero to this bit selects falling-edge interrupts. The Port A Control Register controls external interrupt line EXTIRQ1, while the Port B Control Register controls external interrupt line EXTIRQ2. Reading this bit shows the bit's current state.
0	INTEN	This bit enables and disables the interrupt generation capability of EXTIRQ1 or EXTIRQ2. Writing a one to this bit enables interrupts, while writing a zero to this bit disables interrupts. The Port A Control Register controls EXTIRQ1, while the Port B Control Register controls EXTIRQ2. Reading this bit shows the bit's current state.

Programming Considerations for the Am9513A STCs

Before using the Am9513A STC devices, you must initialize them. To do this, perform the following steps on each of the Am9513A STC devices. All writes are 8-bit write operations. All values are given in hexadecimal.

1. Issue a master reset by writing FF to the Am9513A Command Register.
2. Initialize all five counters. For $ctr = 1$ to 5, follow these steps:
 - Write ctr to the Am9513A Command Register (select the Counter Mode Register).
 - Write 00 to the Am9513A Data Register (store the least significant byte of the counter mode value).
 - Write 00 to the Am9513A Data Register (store the most significant byte of the counter mode value).
 - Write $ctr + 8$ to the Am9513A Command Register (select the Counter Load Register).
 - Write 03 to the Am9513A Data Register (store the least significant byte of the counter load value).
 - Write 00 to the Am9513A Data Register (store the most significant byte of the counter load value).
3. Load all counters with their Counter Load Register values by writing 5F to the Am9513A Command Register.

Note: When you initialize Am9513A STC B, which contains Counters 6 through 10, ctr must range from 1 to 5, *not* from 6 to 10. Also, each Am9513A STC must always be configured to use the 8-bit bus mode in order to function properly.

Programming Example for the Am9513A STCs

The code below lists a sample function that can be used to reset the Am9513A STCs on the PC-TIO-10. In addition, the code lists a sample function that can be used to generate a variable duty-cycle square-wave.

```

/* miscellaneous definitions */

#define cmd_port      0x0001
#define data_port     0x0000
#define no_err        0
#define range_err     -1
#define stc_a         0x0000
#define stc_b         0x0002
#define tio_ba        0x01a0

/* function prototypes */

```

```

void    main(void);
void    reset9513(unsigned int, unsigned int);
int     square_wave(unsigned int, unsigned int, unsigned int, unsigned long,
                  unsigned long);

/* support functions */

void    reset9513(base_address, chip_offset)
    unsigned int    base_address,
                  chip_offset;
{    unsigned int    cmd,
    data;
    int              ctr;

    /* set up the register addresses */

    cmd = base_address | chip_offset | cmd_port;
    data = base_address | chip_offset | data_port;

    /* reset the 9513 */

    outp(cmd, 0xff);          /* reset the chip */
    for (ctr = 1; ctr <=5; ctr++)
        {    outp(cmd, ctr);    /* select Counter Mode Register */
            outp(data, 0x00);    /* store mode low-byte */
            outp(data, 0x00);    /* store mode high-byte */
            outp(cmd, (ctr + 8)); /* select Counter Load Register */
            outp(data, 0x03);    /* store load low-byte */
            outp(data, 0x00);    /* store load high-byte */
        }
    outp(cmd, 0x5f);          /* load all counters */
}

int square_wave(base_address, counter, timebase, high_time, low_time)
    unsigned int    base_address,
                  counter,
                  timebase;
    unsigned long   high_time,
                  low_time;
{    unsigned int    cmd,
    data,
    mode;

    /* check ranges */

    if ((counter < 1) || (counter > 10) ||
        (timebase > 15) ||
        (high_time < 1L) || (high_time > 65536L) ||
        (low_time < 1L) || (low_time > 65536L))
        return range_err;

    /* set up the register addresses */

```

```

cmd = base_address | ((counter > 5) ? stc_b : stc_a) | cmd_port;
data = base_address | ((counter > 5) ? stc_b : stc_a) | data_port;

/* adjust some parameters and program the counter */

if (counter > 5) /* 5 ctrs per chip */
    counter -= 5;
mode = 0x0062 | (timebase << 8); /* counter mode */
if (high_time == 65536L) /* count of 65,536 */
    high_time = 0L; /* goes to 0 */
if (low_time == 65536L) /* count of 65,536 */
    low_time = 0L; /* goes to 0 */

outp(cmd, (0xc0 | (0x01 << (counter - 1)))); /* disarm the ctr */
outp(cmd, counter); /* select Mode Reg */
outp(data, mode); /* send mode
                    low-byte */
outp(data, (mode >> 8)); /* send mode
                    high-byte */
outp(cmd, (counter + 0x08)); /* select Load Reg */
outp(data, ((unsigned int) high_time)); /* send load
                    low-byte */
outp(data, ((unsigned int) (high_time >> 8))); /* send load
                    high-byte */
outp(cmd, (counter + 0x10)); /* select Hold Reg */
outp(data, ((unsigned int) low_time)); /* send hold
                    low-byte */
outp(data, ((unsigned int) (low_time >> 8))); /* send hold
                    high-byte */
outp(cmd, (0x40 | (0x01 << (counter - 1)))); /* load the ctr */
outp(cmd, (0xe8 | counter)); /* set output high */
outp(cmd, (0x20 | (0x01 << (counter - 1)))); /* arm the ctr */

return no_err;
}

/* the main function */

void main()
{ /* reset both 9513s */

    reset9513(tio_ba, stc_a);
    reset9513(tio_ba, stc_b);

    /* start a 100 khz, 70% duty cycle, square wave on Counter 8:
       tio_ba selects the board's base address
       8 selects the counter
       0x000b selects timebase F1, or 1 MHz
       7L selects a high time of 7 µsec
       3L selects a low time of 3 µsec
       a total of 10 µsec/cycle gives a 100 kHz wave
       7 clocks high out of 10 clocks gives a 70% duty cycle
    */

    square_wave(tio_ba, 8, 0x000b, 7L, 3L);
}

```

Interrupt Programming Example for the MC6821

The PC-TIO-10 is configured so that EXTIRQ1 on the I/O connector is connected to CA1 on the MC6821, EXTIRQ2 on the I/O connector is connected to CB1 on the MC6821, and CA2 and CB2 of the MC6821 are disabled. The signal names CA1, CA2, CB1, and CB2 refer to the names of pins located on the MC6821. The names are given to clarify how the interrupt circuitry is connected on the MC6821. For more information on these signals, see Appendix D, *Motorola MC6821 Data Sheet*. Interrupts are enabled and disabled through the MC6821 Control Register. In addition, the edge that generates the interrupt is programmable through the MC6821 Control Register.

When an interrupt is generated (as indicated when the Control Register is read), the only way the interrupt can be cleared is by reading the Output Register (through the Data Register) of the I/O port that indicated the interrupt. For instance, if IRQ in the Port B Control Register is set, you must set DRS of the Port B Control Register to one, and then you must read the Port B Data Register. The data returned may not be important depending on how you are using interrupts.

The code that follows demonstrates how to set up the MC6821 for interrupt generation.

```

/* defines for the program */

#define base_address    0x01A0 /* board located at address 1A0    */
#define porta_offset   0x04 /* offset for Port A    */
#define portb_offset   0x06 /* offset for Port B    */
#define data_offset    0x00 /* offset of Data Register */
#define ctrl_offset    0x01 /* offset of Control Register */
#define irq_channel    5 /* the interrupt channel set on W1 */

/* a sample structure for the interrupt service routine */

typedef struct {
    unsigned int    pa_ctrl,
                  pa_data,
                  pb_ctrl,
                  pb_data;
    int             done;
} isr_block_type;

/* prototypes for the assembly language functions */

void far install_isr(int, isr_block_type far *);
void far remove_isr(void);

/* the main program */

void main()
{
    unsigned int    pa_ctrl,
                  pa_data,
                  pb_ctrl,
                  pb_data;
    isr_block_type isr_block;

    /* calculate register addresses */

```

```

pa_ctrl = base_address + porta_offset + ctrl_offset;
pa_data = base_address + porta_offset + data_offset;
pb_ctrl = base_address + portb_offset + ctrl_offset;
pb_data = base_address + portb_offset + data_offset;

/* clear any active interrupts by reading Data Registers */

outp(pa_ctrl, 0x04); /* select Output Register */
inp(pa_data); /* clear Port A interrupts */
outp(pb_ctrl, 0x04); /* select Output Register */
inp(pb_data); /* clear Port B interrupts */

/* install the interrupt service routine */

isr_block.pa_ctrl = pa_ctrl; /* initialize isr_block */
isr_block.pa_data = pa_data;
isr_block.pb_ctrl = pb_ctrl;
isr_block.pb_data = pb_data;
isr_block.done = 0;
install_isr(irq_channel, &isr_block);

/* configure Ports A and B for interrupts */

outp(pa_ctrl, 0x05); /* enable falling-edge interrupts */
outp(pb_ctrl, 0x07); /* enable rising-edge interrupts */

/* wait for the process to be completed */

while (!isr_block.done)
    /* call_foreground_code() */ ;

/* disable interrupts and remove the interrupt service routine */

outp(pa_ctrl, 0x04);
inp(pa_data);
outp(pb_ctrl, 0x04);
inp(pb_data);
remove_isr();
}

```

Sample code for the functions `install_isr()` and `remove_isr()` is presented as follows. Be sure to pass a 32-bit structure pointer to the `install_isr()` function, because the main program's data will probably be stored in a different memory segment than the one where the interrupt functions are located. In addition, if you call the installation function from a language besides C, make sure the parameters are passed in the proper order. C pushes parameters on the stack from right to left, but most other languages, most notably Pascal, push parameters from left to right. Finally, be sure to make the calls to the functions using 32-bit addresses, because all of the code assumes data is offset with respect to a 32-bit return address. The code can be modified to use 16-bit addresses by changing `far` to `near` and decrementing all references to the base page register, `bp`, by two in `install_isr()` and `remove_isr()` only. *Do not* modify `isr_handler()`.

Also, `isr_handler()` should check, service, and clear both Port A and Port B interrupts before issuing the end-of-interrupt command. If interrupts are still active when the end-of-interrupt command is issued, program operation usually becomes unstable and is likely to lock up the computer.

; assemble this file with the following command:

```
; masm /MX filename;
; /MX preserves case sensitivity
;
;
; function prototypes:
;
; void  install_isr(int level, isr_block_type far * isr_block);
;
;   on input, level indicates the interrupt level that is to be modified
;   on input, isr_block points to the data structure that will be used by
;   the isr_handler function
;
; void  isr_handler(void);
;
;   the isr_handler() function will never be called from C.....
;
; void  remove_isr(void);
;
```

```
public _install_isr, _isr_handler, _remove_isr
```

```
_DATA segment word public 'DATA'
```

```
; declarations
```

```
ackm    equ  00020h
acks    equ  000a0h
eoi     equ  00020h
maskm   equ  00021h
masks   equ  000a1h
```

```
int_addr dd  0
int_mask dw  0
isrb_addr dd 0
slave_ack db 0
vect_num db  0
```

```
_DATA ends
```

```
_TEXT segment word public 'CODE'
    assume cs:_TEXT, ss:_TEXT, ds:_DATA
```

```
; install_isr
;
; bp reg      at [bp+0]
; ret addr ofs at [bp+2]
; ret addr seg at [bp+4]
; level      at [bp+6]
; isr_block ofs at [bp+8]
; isr_block seg at [bp+10]
;
```



```

_install_isr    proc    far
    cli
    push    bp
    mov     bp,sp
    push    ax
    push    bx
    push    cx
    push    dx
    push    ds
    push    es
    mov     ax,seg _DATA
    mov     ds,ax

```

; save the pointer for the isr_block structure--used in isr_handler

```

    mov     ax,[bp+8]        ; get ofs into ax
    mov     word ptr isrb_addr[0],ax ; save address in variable
    mov     ax,[bp+10]       ; get seg into ax
    mov     word ptr isrb_addr[2],ax ; save address in variable

```

; set interrupt vector--save the current vector before writing out new one

```

    mov     ax,[bp+6]        ; get interrupt level
    cmp     al,7            ; check to see if it belongs to master
    ja     short slave      ; or slave interrupt chip
    add     al,008h         ; offset for master vector list
    jmp     short setvec    ; go set the vector
slave:
    add     al,068h         ; offset for slave vector list
    mov     slave_ack,1    ; flag for slave channel
setvec:
    push    ax              ; save vector number for later
    mov     ah,35h         ; get current vector
    int     21h            ; get previous int_addr in es:bx
    pop     ax              ; restore vector number
    mov     cx,cs          ; prep to compare current/new vectors
    mov     dx,es
    cmp     dx,cx          ; see if vector is already there
    jne    short ii_0
    cmp     bx,offset _isr_handler
    je     short ii_exit   ; vector already installed--exit
ii_0:
    mov     vect_num,al    ; save vector number for remove_isr
    mov     word ptr int_addr[0],bx ; save the address
    mov     word ptr int_addr[2],es
    push    ds              ; save the data segment
    mov     ds,cx          ; copy cx (== cs) into ds
    mov     dx,offset _isr_handler ; ds:dx points to new handler
    mov     ah,25h
    int     21h            ; install the handler in the system
    pop     ds

```

; mask interrupt level in the interrupt controller register and store
; the original setting of the mask bit for the selected interrupt level

```

    mov  cx,[bp+6]      ; get interrupt level
    mov  bx,1          ; generate some masks
    shl  bx,cl
    mov  cx,bx        ; cx has 1 in bit pos of int-level
    not  bx           ; bx has 0 in bit pos of int-level
    in   al,maskm     ; get mask data from master chip
    jmp  $+2          ; delay--wait for data transfer
    and  cl,al        ; determine setting of mask bit
    and  al,bl        ; enable interrupts for selected level
    out  maskm,al
    jmp  $+2          ; delay--wait for data transfer
    in   al,masks     ; get mask data from slave chip
    jmp  $+2          ; delay--wait for data transfer
    and  ch,al        ; determine setting of mask bit
    and  al,bh        ; enable interrupts for selected level
    out  masks,al
    mov  int_mask,cx  ; save the previous value of the mask

```

```

; restore saved registers

```

```

ii_exit:

```

```

    pop  es
    pop  ds
    pop  dx
    pop  cx
    pop  bx
    pop  ax
    pop  bp
    sti
    ret
_install_isr  endp

```

```

; remove_isr
;
; bp reg      at [bp+0]
; ret addr ofs at [bp+2]
; ret addr seg at [bp+4]
;

```

```

_remove_isr proc  far
    cli
    push  ax
    push  bx
    push  cx
    push  dx
    push  ds
    push  es
    mov  ax,seg _DATA
    mov  ds,ax

```

```

; see if our vector is installed--if not, do not remove the vector

```

```

    cmp  vect_num,0      ; see if vect_num was ever set
    jz   short ri_exit   ; our vector never installed--exit
    mov  al,vect_num     ; get vector number
    mov  ah,35h         ; get current vector from DOS
    int  21h           ; get previous int_addr in es:bx
    mov  cx,cs          ; prep to compare old/current vectors
    mov  dx,es
    cmp  dx,cx          ; see if our vector is already there
    jne  short ri_exit   ; different vector segment--exit
    cmp  bx,offset_isr_handler
    jne  short ri_exit   ; different vector offset--exit

```

```

; restore old mask and vector values

```

```

    mov  cx,int_mask    ; get the old mask value
    in   al,maskm       ; get current master mask
    jmp  $+2            ; delay--wait for data transfer
    or   al,cl          ; OR in old mask value
    out  maskm,al       ; send out new setting
    jmp  $+2            ; delay--wait for data transfer
    in   al,masks       ; get current slave mask
    jmp  $+2            ; delay--wait for data transfer
    or   al,ch          ; OR in old mask value
    out  masks,al       ; send out new setting
    jmp  $+2            ; delay--wait for data transfer
    mov  al,vect_num    ; al holds interrupt level
    mov  ah,25h
    lds  dx,int_addr    ; ds:dx points to new handler
    int  21h           ; install the old vector

```

```

; restore saved registers

```

```

ri_exit:

```

```

    pop  es
    pop  ds
    pop  dx
    pop  cx
    pop  bx
    pop  ax
    sti
    ret

```

```

_remove_isr endp

```

```

; isr_handler
;

```

```

_isr_handler  proc  far
    cli
    push  ax
    push  ds

```

```

; service interrupt

```

```

; your code here...
; if this was not your interrupt, jump to 'ih_0'
; if this was your interrupt, service it as appropriate;
; the pointer for the data structure 'isr_block' is stored
; at _DATA:isrb_addr; to access the structure, use the
; following steps:
;
;     mov  ax,seg _DATA
;     mov  ds,ax
;     lds  si,isrb_addr
;
; you need not use ds:si, but be sure to save any
; registers you use...

; acknowledge the interrupt

ih_0:
    mov  ax,seg _DATA
    mov  ds,ax
    mov  al,eoi        ; signify end of interrupt
    cmp  slave_ack,0  ; see if we need to acknowledge slave
    je   short ih_1   ; jump if not
    out  acks,al      ; send slave acknowledge
    jmp  $+2          ; delay--wait for data transfer
ih_1:
    out  ackm,al      ; send master acknowledge

; restore saved registers

    pop  ds
    pop  ax
    sti
    iret
_isr_handler    endp

_TEXT    ends
end

```

Appendix A

Specifications

This appendix lists the specifications of the PC-TIO-10. These specifications are typical at 25° C, unless otherwise stated. The operating temperature range is 0° to 70° C.

I/O Connector Electrical Specifications

I/O Signal Ratings

Absolute maximum voltage rating -0.3 to +7.0 V with respect to GND

Input Signal Specifications

	Minimum	Maximum
Input logic high voltage, all inputs	2.0 V	5.25 V
Input logic low voltage, all inputs	0.0 V	0.8 V
Input current, Am9513A ($0 < V_{in} < 5.25$ V)	-10 μ A	10 μ A
Input current, MC6821, Port A ($0 < V_{in} < 0.8$ V)	–	-2.4 mA
Input current, MC6821, Port A ($2.0 < V_{in} < 5.25$ V)	–	-400 μ A
Input current, MC6821, Port B ($0.4 < V_{in} < 2.4$ V)	–	10 μ A
Input current, MC6821, EXTIRQ1 and EXTIRQ2 ($0 < V_{in} < 5.25$ V)	–	2.5 μ A
Pulse width, Am9513A, source inputs	70 nsec	–
Pulse width, Am9513A, gate inputs	145 nsec	–
Pulse width, MC6821, EXTIRQ1 and EXTIRQ2	100 nsec	–

Output Signal Specifications

Pin 34 at +5 V 1.0 A maximum

Note: The total current output from pin 34 may be limited by the available current from your computer's power supply. To determine the available current, subtract the maximum power consumption of the board from the maximum current per slot. The difference, if less than 1 A, is the maximum current available to pin 34. If the difference is equal to or greater than 1 A, the maximum current available is restricted by the limitations of the connector, as shown previously.

	Minimum	Maximum
Output logic high voltage, all outputs at $I_{out} = -200 \mu A$	2.4 V	5.0 V
Output logic low voltage, all outputs at $I_{out} = 3.2 \text{ mA}$	0.0 V	0.4 V
Darlington drive current, MC6821, Port B at $V_{EXT} = 1.5 \text{ V}$	-1.0 mA	-10.0 mA

Operating Environment

Temperature	0° to 70° C
Relative humidity	5% to 90% noncondensing

Storage Environment

Temperature	-55° to 150° C
Relative humidity	5% to 90% noncondensing

Physical

Dimensions	3.9 in. by 4.75 in.
I/O connector	50-pin male ribbon cable connector

Power Requirement (from PC I/O Channel)

Typical power	0.6 A at 5 VDC ($\pm 5\%$)
Maximum power	1.4 A at 5 VDC ($\pm 5\%$)

Note: These power usage figures do not include the power used by external devices that are connected to the fused supply present on the I/O connector.

Appendix B

I/O Connector

This appendix describes the pinout and signal names for the I/O connector on the PC-TIO-10.

Figure B-1 shows the PC-TIO-10 I/O connector.

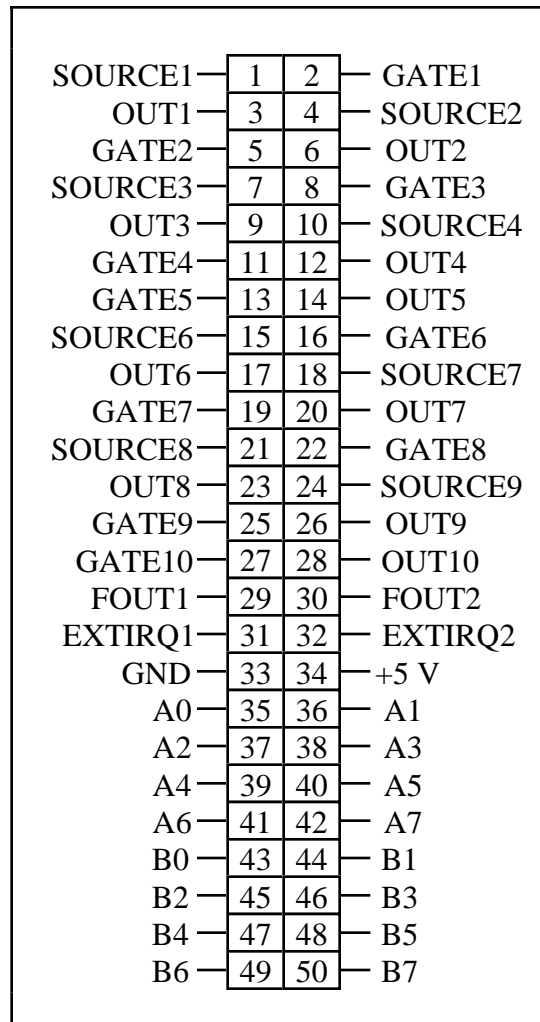

Figure B-1. PC-TIO-10 I/O Connector

Detailed signal specifications are included in Chapter 2, *Configuration and Installation*, and in Appendix A, *Specifications*.

Appendix C

AMD Am9513A Data Sheet*

This appendix contains the manufacturer data sheet for the AMD Am9513A integrated circuit (Advanced Micro Devices, Inc.). This circuit is used on the PC-TIO-10 board.

* Copyright © Advanced Micro Devices, Inc. 1989. Reprinted with permission of copyright owner. All rights reserved.
Advanced Micro Devices, Inc. 1990 Data Book *Personal Computer Products: Processors, Coprocessors, Video, and Mass Storage*.

Appendix D

Motorola MC6821 Data Sheet*

This appendix contains the manufacturer data sheet for the Motorola MC6821 integrated circuit (Motorola, Inc.). This circuit is used on the PC-TIO-10 board.

* Copyright © Motorola, Inc. 1988. Reprinted with permission of copyright owner.
All rights reserved.
Motorola, Inc. Q3/1988 Data Book *Microprocessor, Microcontroller and Peripheral Data, Volume II.*

Appendix E

Switch Settings

Table E-1 lists the possible switch settings, the corresponding base I/O address, and the base I/O address space used for that setting.

Table E-1. Switch Settings with Corresponding Base I/O Address and Base I/O Address Space

Switch Setting A9 A8 A7 A6 A5 A4 A3	Base I/O Address (hex)	Base I/O Address Space Used (hex)
0 0 0 0 0 0 0	000	000 - 007
0 0 0 0 0 0 1	008	008 - 00F
0 0 0 0 0 1 0	010	010 - 017
0 0 0 0 0 1 1	018	018 - 01F
0 0 0 0 1 0 0	020	020 - 027
0 0 0 0 1 0 1	028	028 - 02F
0 0 0 0 1 1 0	030	030 - 037
0 0 0 0 1 1 1	038	038 - 03F
0 0 0 1 0 0 0	040	040 - 047
0 0 0 1 0 0 1	048	048 - 04F
0 0 0 1 0 1 0	050	050 - 057
0 0 0 1 0 1 1	058	058 - 05F
0 0 0 1 1 0 0	060	060 - 067
0 0 0 1 1 0 1	068	068 - 06F
0 0 0 1 1 1 0	070	070 - 077
0 0 0 1 1 1 1	078	078 - 07F
0 0 1 0 0 0 0	080	080 - 087
0 0 1 0 0 0 1	088	088 - 08F
0 0 1 0 0 1 0	090	090 - 097
0 0 1 0 0 1 1	098	098 - 09F
0 0 1 0 1 0 0	0A0	0A0 - 0A7
0 0 1 0 1 0 1	0A8	0A8 - 0AF
0 0 1 0 1 1 0	0B0	0B0 - 0B7
0 0 1 0 1 1 1	0B8	0B8 - 0BF
0 0 1 1 0 0 0	0C0	0C0 - 0C7
0 0 1 1 0 0 1	0C8	0C8 - 0CF
0 0 1 1 0 1 0	0D0	0D0 - 0D7

Note: Base I/O address values 000 through 0FF hex are reserved for system use.
Base I/O address values 100 through 3FF hex are available on the I/O channel.

(continues)

Table E-1. Switch Settings with Corresponding Base I/O Address and Base I/O Address Space (continued)

Switch Setting A9 A8 A7 A6 A5 A4 A3	Base I/O Address (hex)	Base I/O Address Space Used (hex)
0 0 1 1 0 1 1	0D8	0D8 - 0DF
0 0 1 1 1 0 0	0E0	0E0 - 0E7
0 0 1 1 1 0 1	0E8	0E8 - 0EF
0 0 1 1 1 1 0	0F0	0F0 - 0F7
0 0 1 1 1 1 1	0F8	0F8 - 0FF
0 1 0 0 0 0 0	100	100 - 107
0 1 0 0 0 0 1	108	108 - 10F
0 1 0 0 0 1 0	110	110 - 117
0 1 0 0 0 1 1	118	118 - 11F
0 1 0 0 1 0 0	120	120 - 127
0 1 0 0 1 0 1	128	128 - 12F
0 1 0 0 1 1 0	130	130 - 137
0 1 0 0 1 1 1	138	138 - 13F
0 1 0 1 0 0 0	140	140 - 147
0 1 0 1 0 0 1	148	148 - 14F
0 1 0 1 0 1 0	150	150 - 157
0 1 0 1 0 1 1	158	158 - 15F
0 1 0 1 1 0 0	160	160 - 167
0 1 0 1 1 0 1	168	168 - 16F
0 1 0 1 1 1 0	170	170 - 177
0 1 0 1 1 1 1	178	178 - 17F
0 1 1 0 0 0 0	180	180 - 187
0 1 1 0 0 0 1	188	188 - 18F
0 1 1 0 0 1 0	190	190 - 197
0 1 1 0 0 1 1	198	198 - 19F
0 1 1 0 1 0 0	1A0	1A0 - 1A7
0 1 1 0 1 0 1	1A8	1A8 - 1AF
0 1 1 0 1 1 0	1B0	1B0 - 1B7
0 1 1 0 1 1 1	1B8	1B8 - 1BF
0 1 1 1 0 0 0	1C0	1C0 - 1C7
0 1 1 1 0 0 1	1C8	1C8 - 1CF
0 1 1 1 0 1 0	1D0	1D0 - 1D7
0 1 1 1 0 1 1	1D8	1D8 - 1DF
0 1 1 1 1 0 0	1E0	1E0 - 1E7
0 1 1 1 1 0 1	1E8	1E8 - 1EF
0 1 1 1 1 1 0	1F0	1F0 - 1F7
0 1 1 1 1 1 1	1F8	1F8 - 1FF
1 0 0 0 0 0 0	200	200 - 207

Note: Base I/O address values 000 through 0FF hex are reserved for system use. Base I/O address values 100 through 3FF hex are available on the I/O channel.

(continues)

Table E-1. Switch Settings with Corresponding Base I/O Address and Base I/O Address Space (continued)

Switch Setting A9 A8 A7 A6 A5 A4 A3	Base I/O Address (hex)	Base I/O Address Space Used (hex)
1 0 0 0 0 0 1	208	208 - 20F
1 0 0 0 0 1 0	210	210 - 217
1 0 0 0 0 1 1	218	218 - 21F
1 0 0 0 1 0 0	220	220 - 227
1 0 0 0 1 0 1	228	228 - 22F
1 0 0 0 1 1 0	230	230 - 237
1 0 0 0 1 1 1	238	238 - 23F
1 0 0 1 0 0 0	240	240 - 247
1 0 0 1 0 0 1	248	248 - 24F
1 0 0 1 0 1 0	250	250 - 257
1 0 0 1 0 1 1	258	258 - 25F
1 0 0 1 1 0 0	260	260 - 267
1 0 0 1 1 0 1	268	268 - 26F
1 0 0 1 1 1 0	270	270 - 277
1 0 0 1 1 1 1	278	278 - 27F
1 0 1 0 0 0 0	280	280 - 287
1 0 1 0 0 0 1	288	288 - 28F
1 0 1 0 0 1 0	290	290 - 297
1 0 1 0 0 1 1	298	298 - 29F
1 0 1 0 1 0 0	2A0	2A0 - 2A7
1 0 1 0 1 0 1	2A8	2A8 - 2AF
1 0 1 0 1 1 0	2B0	2B0 - 2B7
1 0 1 0 1 1 1	2B8	2B8 - 2BF
1 0 1 1 0 0 0	2C0	2C0 - 2C7
1 0 1 1 0 0 1	2C8	2C8 - 2CF
1 0 1 1 0 1 0	2D0	2D0 - 2D7
1 0 1 1 0 1 1	2D8	2D8 - 2DF
1 0 1 1 1 0 0	2E0	2E0 - 2E7
1 0 1 1 1 0 1	2E8	2E8 - 2EF
1 0 1 1 1 1 0	2F0	2F0 - 2F7
1 0 1 1 1 1 1	2F8	2F8 - 2FF
1 1 0 0 0 0 0	300	300 - 307
1 1 0 0 0 0 1	308	308 - 30F
1 1 0 0 0 1 0	310	310 - 317
1 1 0 0 0 1 1	318	318 - 31F
1 1 0 0 1 0 0	320	320 - 327
1 1 0 0 1 0 1	328	328 - 32F

Note: Base I/O address values 000 through 0FF hex are reserved for system use.
Base I/O address values 100 through 3FF hex are available on the I/O channel.

(continues)

Table E-1. Switch Settings with Corresponding Base I/O Address and Base I/O Address Space (continued)

Switch Setting A9 A8 A7 A6 A5 A4 A3	Base I/O Address (hex)	Base I/O Address Space Used (hex)
1 1 0 0 1 1 0	330	330 - 337
1 1 0 0 1 1 1	338	338 - 33F
1 1 0 1 0 0 0	340	340 - 347
1 1 0 1 0 0 1	348	348 - 34F
1 1 0 1 0 1 0	350	350 - 357
1 1 0 1 0 1 1	358	358 - 35F
1 1 0 1 1 0 0	360	360 - 367
1 1 0 1 1 0 1	368	368 - 36F
1 1 0 1 1 1 0	370	370 - 377
1 1 0 1 1 1 1	378	378 - 37F
1 1 1 0 0 0 0	380	380 - 387
1 1 1 0 0 0 1	388	388 - 38F
1 1 1 0 0 1 0	390	390 - 397
1 1 1 0 0 1 1	398	398 - 39F
1 1 1 0 1 0 0	3A0	3A0 - 3A7
1 1 1 0 1 0 1	3A8	3A8 - 3AF
1 1 1 0 1 1 0	3B0	3B0 - 3B7
1 1 1 0 1 1 1	3B8	3B8 - 3BF
1 1 1 1 0 0 0	3C0	3C0 - 3C7
1 1 1 1 0 0 1	3C8	3C8 - 3CF
1 1 1 1 0 1 0	3D0	3D0 - 3D7
1 1 1 1 0 1 1	3D8	3D8 - 3DF
1 1 1 1 1 0 0	3E0	3E0 - 3E7
1 1 1 1 1 0 1	3E8	3E8 - 3EF
1 1 1 1 1 1 0	3F0	3F0 - 3F7
1 1 1 1 1 1 1	3F8	3F8 - 3FF

Note: Base I/O address values 000 through 0FF hex are reserved for system use.
Base I/O address values 100 through 3FF hex are available on the I/O channel.

Appendix F

Customer Communication

For your convenience, this appendix contains forms to help you gather the information necessary to help us solve technical problems you might have as well as a form you can use to comment on the product documentation. Filling out a copy of the *Technical Support Form* before contacting National Instruments helps us help you better and faster.

National Instruments provides comprehensive technical assistance around the world. In the U.S. and Canada, applications engineers are available Monday through Friday from 8:00 a.m. to 6:00 p.m. (central time). In other countries, contact the nearest branch office. You may fax questions to us at any time.

Corporate Headquarters

(512) 795-8248

Technical support fax: (800) 328-2203

(512) 794-5678

Branch Offices	Phone Number	Fax Number
Australia	(03) 879 9422	(03) 879 9179
Austria	(0662) 435986	(0662) 437010-19
Belgium	02/757.00.20	02/757.03.11
Denmark	45 76 26 00	45 76 71 11
Finland	(90) 527 2321	(90) 502 2930
France	(1) 48 14 24 00	(1) 48 14 24 14
Germany	089/741 31 30	089/714 60 35
Italy	02/48301892	02/48301915
Japan	(03) 3788-1921	(03) 3788-1923
Mexico	95 800 010 0793	95 800 010 0793
Netherlands	03480-33466	03480-30673
Norway	32-848400	32-848600
Singapore	2265886	2265887
Spain	(91) 640 0085	(91) 640 0533
Sweden	08-730 49 70	08-730 43 70
Switzerland	056/20 51 51	056/20 51 55
Taiwan	02 377 1200	02 737 4644
U.K.	0635 523545	0635 523154

Technical Support Form

Photocopy this form and update it each time you make changes to your software or hardware, and use the completed copy of this form as a reference for your current configuration. Completing this form accurately before contacting National Instruments for technical support helps our applications engineers answer your questions more efficiently.

If you are using any National Instruments hardware or software products related to this problem, include the configuration forms from their user manuals. Include additional pages if necessary.

Name _____

Company _____

Address _____

Fax (___) _____ Phone (___) _____

Computer brand _____ Model _____ Processor _____

Operating system _____

Speed _____ MHz RAM _____ M Display adapter _____

Mouse _____ yes _____ no Other adapters installed _____

Hard disk capacity _____ M Brand _____

Instruments used _____

National Instruments hardware product model _____ Revision _____

Configuration _____

National Instruments software product _____ Version _____

Configuration _____

The problem is _____

List any error messages _____

The following steps will reproduce the problem _____

PC-TIO-10 Hardware and Software Configuration Form

Record the settings and revisions of your hardware and software on the line to the right of each item. Complete a new copy of this form each time you revise your software or hardware configuration, and use this form as a reference for your current configuration. Completing this form accurately before contacting National Instruments for technical support helps our applications engineers answer your questions more efficiently.

National Instruments Products

- Base I/O Address of PC-TIO-10
(Factory Setting: hex 1A0) _____
- Interrupt Level of PC-TIO-10
(Factory Setting: 5) _____
- Local Interrupts of PC-TIO-10
(Factory Settings: N.C. and N.C.) _____
- NI-DAQ or LabWindows Version _____

Other Products

- Computer Make and Model _____
- Computer Bus (XT/AT/ISA or EISA) _____
- Microprocessor _____
- Clock Frequency
(Bus and Microprocessor) _____
- Type of Video Board Installed _____
- DOS Version _____
- Programming Language _____
- Programming Language Version _____
- Other Boards in System _____
- Base I/O Address of Other Boards _____
- Interrupt Level of Other Boards _____

Documentation Comment Form

National Instruments encourages you to comment on the documentation supplied with our products. This information helps us provide quality products to meet your needs.

Title: **PC-TIO-10 User Manual**

Edition Date: **July 1993**

Part Number: **320292-01**

Please comment on the completeness, clarity, and organization of the manual.

If you find errors in the manual, please record the page numbers and describe the errors.

Thank you for your help.

Name _____

Title _____

Company _____

Address _____

Phone (_____) _____

Mail to: Technical Publications
National Instruments Corporation
6504 Bridge Point Parkway, MS 53-02
Austin, TX 78730-5039

Fax to: Technical Publications
National Instruments Corporation
MS 53-02
(512) 794-5678

Index

Numbers/Symbols

+5 V signal, 2-8, 2-15

A

A0 through A7 signals, 2-8

Am9513A System Timing Controller

alarm registers and comparators, C-11

block diagram, C-2

characteristics, C-2

command descriptions, C-29 to C-32

connection diagrams, C-3

count control, C-28

count source selection, C-29

counter logic groups, C-8

counter mode control options, C-26 to C-29

counter mode descriptions, C-14 to C-26

counter mode register, C-11

counter mode register bit assignments, C-27

counter output waveforms, C-28

data bus assignments, C-7

data pointer sequencing, C-10

data port registers, C-11

detailed description, C-8 to C-11

general description, C-2

hardware retriggering, C-29

hold register, C-11

input circuitry, C-7

interface considerations, C-7

interface signal summary, C-7

load data pointer commands, C-10

load register, C-11

master mode control options, C-11 to C-13

master mode register bit assignments, C-12

mode waveforms, C-15 to C-26

ordering information, C-3 to C-5

output control, C-26 to C-28

output control logic, C-27

overview, 3-2

pin description, C-6

prefetch circuit, C-10

specifications, C-33 to C-38

status register, C-10 to C-11

TC (terminal count), C-28

- Am9513A Command Registers
 - description of, 4-5
 - register map, 4-2
- Am9513A Data Registers
 - description of, 4-4
 - register map, 4-2
- Am9513A Status Registers
 - description of, 4-6
 - register map, 4-2
- Am9513A STC devices
 - programming considerations, 4-10
 - programming example, 4-10 to 4-13

B

- B0 through B7 signals, 2-8
- base I/O address
 - default settings for National Instrument products, 2-4
 - factory setting, 2-1
 - switch settings, 2-2 to 2-3
 - switch settings with corresponding base I/O address and base I/O address space, E-1 to E-4
- board configuration. *See* configuration.
- BYTE POINTER bit, 4-6

C

- C<7..0> bit, 4-5
- cabling, 2-16
- CB-50 cable, 2-16
- configuration
 - base I/O address
 - factory settings, 2-1
 - switch settings for, 2-2 to 2-3
 - default settings for National Instrument products, 2-4
 - interrupt level selection, 2-4 to 2-5
 - local interrupt selection, 2-5
 - parts locator diagram, 2-2
 - switch and jumper factory settings, 2-1
- customer communication, *vii*

D

- D<7..0> bit, 4-4, 4-8
- D<15..8> bit, 4-4
- data transceivers, 3-2
- digital I/O signal connections, 2-13 to 2-14
 - illustration of, 2-14
 - specifications and ratings, 2-13 to 2-14
 - timing and digital I/O connector, 3-3

DMA channel default settings, 2-4
documentation

- abbreviations used in the manual, *vi to vii*
- acronyms used in the manual, *vii*
- conventions used in the manual, *vi*
- related documentation, *vii*

DRS bit, 4-9

E

EDGE bit, 4-9
equipment, optional, 1-3
event-counting application, 2-10
EXTIRQ1 through EXTIRQ2 signals, 2-8

F

FOUT1 through FOUT2 signals, 2-8, 2-9, 2-11 to 2-12
frequency measurement, 2-10 to 2-11

G

GATE1 through GATE10 signals, 2-8, 2-10 to 2-13
GND signal, 2-8

I

I/O connector pin description, 2-7, B-1
I/O signal ratings. *See* specifications and ratings.
input signal specifications, A-1
installation

- cabling, 2-16
- procedure for, 2-6
- unpacking the PC-TIO-10, 1-4

INTEN bit, 4-9
interrupt level

- default settings for National Instrument products, 2-4
- jumpers for interrupt level selection, 2-4 to 2-5
- local interrupt selection, 2-5
- programming example for the MC6821, 4-13 to 4-19
- theory of operation, 3-2

IRQ bit, 4-9

J

jumpers and switches

- base I/O address switch settings, 2-2 to 2-3
- example base I/O address switch settings, 2-3

- factory settings, 2-1
- interrupt jumper settings, 2-4
- local interrupt jumper setting, 2-5
- parts locator diagram, 2-2
- switch settings with corresponding base I/O address and base I/O address space, E-1 to E-4

K

kit, contents of, 1-2

L

LabWindows software, 1-3

M

MC6821 Control Registers

- description of, 4-9

- register map, 4-2

MC6821 Data Registers

- description of, 4-8

- register map, 4-2

MC6821 Peripheral Interface Adapter

- block diagram, D-7

- bus timing characteristics, D-4

- control registers, D-9

- control word format, D-11

- data direction access control bit, D-9 to D-10

- electrical characteristics, D-3 to D-4

- functions of, D-2

- initialization, D-9

- interface signals for MPU, D-8

- internal controls, D-9 to D-11

- maximum ratings, D-3

- ordering information, D-10

- overview, 3-2

- peripheral interface lines, D-8 to D-9

- peripheral timing characteristics, D-5 to D-7

- pin assignments, D-12

- port A-B hardware characteristics, D-9

- power considerations, D-3

- programming example, 4-13 to 4-19

- specifications and ratings, D-3 to D-7

N

NI-DAQ software, 1-3

O

operating environment specifications, A-2
 operation of PC-TIO-10. *See* theory of operation.
 optional equipment, 1-3
 optional software, 1-3
 OUT<5..1> bit, 4-6
 OUT1 through OUT10 signals, 2-8, 2-11 to 2-13
 output signal specifications, A-1 to A-2

P

PC I/O channel control circuitry, 3-2
 PC-TIO-10. *See also* theory of operation.
 block diagram, 3-1
 functions of, 1-2
 illustration of, 1-1
 overview, v, 1-1
 physical specifications, A-2
 pin description
 Am9513A System Timing Controller, C-6
 MC6821 Peripheral Interface Adapter, D-12
 PC-TIO-10 I/O connector, 2-7, B-1
 port, definition of, 4-1
 power connections, 2-15
 power requirement, A-2
 programming
 Am9513A Command Registers, 4-5
 Am9513A Data Registers, 4-4
 Am9513A Status Registers, 4-6
 Am9513A STC devices, 4-10 to 4-13
 interrupt programming example for the MC6821, 4-13 to 4-19
 MC6821 Control Registers, 4-9
 MC6821 Data Registers, 4-8
 overview, 4-1
 register map, 4-2
 pulse-width measurements, 2-10

R

registers. *See also* programming.
 Am9513A Command Registers, 4-5
 Am9513A Data Registers, 4-4
 Am9513A Status Registers, 4-6
 definition of, 4-1
 MC6821 Control Registers, 4-9
 MC6821 Data Registers, 4-8

overview, 4-1
register map, 4-2

S

signal connections
 damage caused by exceeding maximum ratings, 2-6
 description of, 2-8
 digital I/O signal connections, 2-13 to 2-14
 I/O connector pin description, 2-6, B-1
 power connections, 2-15
 timing signal connections, 2-9 to 2-13
software, optional, 1-2 to 1-3
SOURCE signals, 2-10 to 2-13
SOURCE1 through SOURCE4 signals, 2-8
SOURCE6 through SOURCE9 signals, 2-8
specifications and ratings
 Am9513A System Timing Controller, C-33 to C-38
 Am9513A digital input, 2-11
 Am9513A digital output, 2-12
 Am9513A I/O signals, 2-11
 digital I/O lines, 2-13
 digital input, 2-13
 digital output, 2-14
 I/O connector electrical specifications, A-1 to A-2
 I/O signal ratings, A-1
 input signal specifications, A-1
 MC6821 Peripheral Interface Adapter, D-3 to D-7
 operating environment, A-2
 output signal specifications, A-1 to A-2
 physical specifications, A-2
 power connections, 2-15
 power requirement, A-2
 storage environment, A-2
storage environment specifications, A-2
support, technical, *vii*
switches. *See* jumpers and switches.

T

technical support, *vii*
theory of operation
 Am9513A system timing controller, 3-2
 block diagram, 3-1
 data transceivers, 3-2
 interrupt control circuitry, 3-2
 MC6821 Peripheral Interface Adapter, 3-2

- PC I/O channel control circuitry, 3-2
- timing and digital I/O connector, 3-3
- time-lapse measurements, 2-10
- timing signal connections, 2-11 to 2-13
 - event-counting application, 2-10
 - frequency measurement, 2-10 to 2-11
 - overview, 2-9
 - pulse-width measurements, 2-10
 - specifications and ratings, 2-11 to 2-12
 - time-lapse measurements, 2-10
 - timing and digital I/O connector, 3-3
 - timing signal relationships, 2-12

U

- unpacking the PC-TIO-10, 1-4
- unused bits (X), 4-6